



TECHNISCHE  
UNIVERSITÄT  
WIEN  
Vienna University of Technology

**Diplomarbeit**  
**QUANTIFICATION OF TOTAL CYANIDE CONTENT**  
**IN KERNELS OF STONE FRUITS**

ausgeführt zum Zwecke der Erlangung des akademischen Grades eines

**Diplom-Ingenieurs**

unter der Leitung von

**Ao.Univ.Prof. Dipl.-Ing. Dr.techn. Ingrid Steiner**

(E166 Institut für Verfahrenstechnik, Umwelttechnik und Technische Biowissenschaften)

eingereicht an der Technischen Universität Wien

**Fakultät für Technische Chemie**

von

**Anatol Maurice Desser**

9625123

Wien, im April 2015

---

Anatol Maurice Desser



TECHNISCHE  
UNIVERSITÄT  
WIEN  
Vienna University of Technology

Ich habe zur Kenntnis genommen, dass ich zur Drucklegung meiner Arbeit unter der Bezeichnung

## **Diplomarbeit**

nur mit Bewilligung der Prüfungskommission berechtigt bin.

Ich erkläre weiters Eides statt, dass ich meine Diplomarbeit nach den anerkannten Grundsätzen für wissenschaftliche Abhandlungen selbstständig ausgeführt habe und alle verwendeten Hilfsmittel, insbesondere die zugrunde gelegte Literatur, genannt habe.

Weiters erkläre ich, dass ich dieses Diplomarbeitsthema bisher weder im In- noch Ausland (einer Beurteilerin/einen Beurteiler zur Begutachtung) in irgendeiner Form als Prüfungsarbeit vorgelegt habe und dass diese Arbeit mit der vom Begutachter beurteilten Arbeit übereinstimmt.

Wien, im April 2015

---

Anatol Maurice Desser

## **Danksagung**

An dieser Stelle möchte ich mich bei meinen Eltern Dr. Lucia und Dr. Hans Desser bedanken, die mir durch ihre finanzielle und moralische Unterstützung - besonders in schwierigen Situationen - mein Studium ermöglicht haben.

Für ihre hilfreiche Unterstützung bei meiner Arbeit möchte ich mich auch den Mitarbeitern der Arbeitsgruppe Lebensmittelchemie für die gute Zusammenarbeit, ganz besonders meinen Kollegen Bernd Trimmel und DI Kathrin Scharnhorst, meiner Betreuerin Prof. Dr. Ingrid Steiner und Herbert Hafner bedanken.

Mein Dank gilt ebenfalls Dr. Gerd Mauschitz für seine Hilfe bei der Laserdiffraktometrie.

---

## Abstract

Many plants from the genus *Prunus* deliver fruits which are popular food or pre product in many parts of the world. The kernels of those fruits vastly remain unprocessed and are disposed of, because of the high content of cyanogenic glycosides which refers to up to 2500 mg HCN per kg plant material. Therefore it is crucial to be aware of the total cyanide content and to apply appropriate methods of decontamination to allow industrial use.

In this work the method of determination of total cyanide with picric acid was adapted for analysis of stone fruit kernels. The content of total cyanide was determined photometrically according to the reaction of HCN with picric acid to isopurpuric acid on a test strip and expressed in mg HCN per kg food sample.

In the different stone fruit kernels (apricot, sort cherry and bitter almond) the content of total cyanide was determined to be in a range of 800 to 2400 mg/kg. In stone fruit kernels from sweet cultivars (sweet almond) no cyanide was determined. In products made from stone fruit kernels (roasted kernels, persipan) cyanide was determined to be in a range of 60-173 mg per kg food sample. In other products made from stone fruit kernels (marzipan, marzipan filling, chocolate) no cyanide was detected.

Several methods of decontamination were tested: continuous flow and batch by water, batch by ethanol, heat and fermentation with  $\beta$ -glucosidase. It was shown that satisfying decontamination can be achieved simply with cold water. The HCN content of apricot kernels was reduced by 80% in a 24h batch process using cold water.

The results of this study indicate that stone fruit kernels and kernel products can be used in the food industry after an appropriate decontamination step. Furthermore it was shown that the method of determining the HCN content with picric acid on a test strip can be used for rapid analysis.

## Contents

1. Introduction and objectives.....	8
1.1 Introduction.....	8
1.2 Objectives.....	8
2. Principles.....	9
2.1 Cyanogenic glycosides and cyanogenesis.....	9
2.1.1 General.....	9
2.1.2 Biosynthesis.....	11
2.1.3 Occurrence .....	13
2.1.4 $\beta$ -Glucosidases.....	14
2.1.5 Toxicity.....	14
2.1.5.1 Absorption, distribution and excretion.....	16
2.1.5.2 Toxic Effects.....	16
2.1.5.3 Mechanism.....	17
2.1.5.4 Detoxification.....	17
2.1.5.5 Symptoms of poisoning.....	18
2.1.5.6 Treatment .....	18
2.1.6 Physical and chemical properties of stone fruit kernels .....	18
2.1.6.1 Physical and chemical properties of apricot kernels.....	18
2.1.6.2 Chemical composition of sour cherry kernels.....	20
2.2 Determination of cyanogenic potential in stone fruit kernels and their products.....	20
2.2.1 Norm method: determination of hydrocyanic acid in marzipan, persipan and their prestages by distillation and titration.....	20
2.2.2 Norm Method: Animal feeding stuffs — Determination of Hydrocyanic acid by HPLC .....	20
2.2.3 Determination of cyanide content by chemical or enzymatic hydrolysis of the cyanogenic glycosides (CG) and quantification of cyanide.....	21
2.2.4 Determination of amygdalin by chromatographic methods .....	21
2.2.4.1 Determination of amygdalin by high pressure liquid chromatography HPLC .....	21
2.2.4.2 Determination of amygdalin by gas chromatography GC/MS.....	22
2.2.4.3 Determination of amygdalin by micellar electrokinetic chromatography (MEKC).....	22
2.2.5 Determination of amygdalin by enzyme-immunoassay.....	22
2.3 Decontamination methods.....	23
2.3.1 Decontamination by water.....	23

2.3.2 Decontamination with ethanol.....	23
2.3.3 Decontamination by fermentation with $\beta$ -glycosidase (autodecontamination) .....	23
2.4 Processing options of stone-fruit kernels containing cyanogenic compounds.....	24
2.4.1 Overview.....	24
2.4.1 Separation of the apricot kernels from the pits.....	25
2.4.2 Kernel processing .....	28
2.4.2.1 Production of edible apricot oil.....	28
2.4.2.2 Production of natural benzaldehyde from stone fruit kernels.....	28
2.4.2.2.1 Principles.....	28
2.4.2.2.2 Production of natural benzaldehyde.....	29
2.4.2.2.2.1 Recovery of wastewater containing benzaldehyde by simultaneous distillation- extraction (SDE).....	29
2.4.2.2.2.2 Base-catalysed production from natural cinnamaldehyde .....	29
2.4.2.2.2.3 Extraction by microwave .....	29
2.4.2.2.2.4 Quantification of benzaldehyde in the product.....	29
2.4.2.3 Production of persipan.....	29
2.4.2.4 Antioxidant properties of roasted apricot kernel flours.....	30
2.4.3 Processing kernels from other stone fruits.....	30
3. Materials.....	31
3.1 Sample Materials.....	31
3.2 Laboratory devices.....	32
3.3 Chemicals.....	32
4. Methods.....	33
4.1 Picrate method for determination of total cyanide in prunus kernels.....	33
4.1.1 Principle.....	33
4.1.2 Sample Preparation and preparation of picrate paper test strips.....	33
4.1.2.1 Preparation of picrate paper test strips.....	33
4.1.2.2 Preparation of homogeneous food samples like marzipan or persipan.....	33
4.1.2.3 Preparation of apricot kernels.....	34
4.1.2.4 Preparation of sour cherry kernels.....	34
4.1.3 Quantification of the total cyanide content in the prepared sample.....	34
4.1.4 Method validation.....	37
4.1.4.1 Working range.....	37
4.1.4.2 Linearity.....	37
4.1.4.3 Limit of detection.....	38
4.1.4.4 Limit of quantification.....	38

4.1.4.5 Precision.....	39
4.1.4.6 Selectivity.....	39
4.2 Decontamination.....	40
4.2.1 Decontamination using water .....	40
4.2.1.1 Continuous flow decontamination.....	40
4.2.1.2 Batch decontamination.....	40
4.2.1 Decontamination using ethanol.....	40
4.2.1 Decontamination by heat treatment.....	41
5. Results.....	42
5.1 Preliminary tests and observations.....	42
5.1.1 Apricot.....	42
5.1.2 Sour Cherry.....	43
5.2 Total HCN content in stone fruit kernels and foods containing these.....	44
5.3 Effects of debittering.....	46
5.3.1 Effects of debittering by leaching in water.....	46
5.3.1.1 Continuous flow debittering.....	46
5.3.1.2 Batch debittering.....	47
5.3.2 Effects of debittering by leaching in ethanol.....	48
5.3.3 Effects of debittering by heat treatment.....	48
5.4 Particle size distribution .....	48
6. Discussion.....	52
6.1 Method.....	52
6.2 Sustainability of stone fruit kernels.....	52
6.3 Toxicity of stone fruit kernel products.....	53
6.4 Labelling obligation of food products with hydrocyanogenic potential.....	54
6.5 Conclusion and outlook.....	55
7. Abbreviations.....	56
References.....	57

## **1. Introduction and objectives**

### **1.1 Introduction**

Due to the natural limitation of non-renewable resource it is generally sensible to achieve new and more effective possibilities of using renewable primary products if this is technically possible and economically reasonable. Stone fruit kernels are rich in edible oil of high quality, proteins and fibres and therefore an example of a vast unused source for renewable primary products. They can be used in production of edible oil, cosmetics, drugs and scents, whereas the pits can be used for fuel and heat production (1) (2).

Since the use of stone fruit kernels is connected with some technical problems, such as crushing the stones properly without damaging the kernel, separation of the kernel from the pit (1) and detoxification of the amygdalin-containing kernel, most stones produced in the EU are composted or used as fuel for heat production (2), without separating and processing the kernel to valuable secondary products.

The indirect toxicity of amygdalin which is decomposed by the enzyme  $\beta$ -glucosidase to benzaldehyde, glucose and prussic acid represents a potential danger for the consumer.

The Austrian food law allows 50 mg/kg in nougat, marzipan, alternative products and similar products, 5 mg HCN/kg in stone fruit preserves and 35 mg/kg in alcoholic drinks (3).

1 mg hydrocyanic acid corresponds to approximately 17 mg amygdalin. Because the decomposition product natural benzaldehyde (bitter almond oil) is an important flavouring substance for various aromas it is important to learn more about the decomposition process in order to optimize the detoxification of stone fruit kernels from hydrocyanic acid and the utilisation of benzaldehyde.

### **1.2 Objectives**

The purpose of this work is to discuss and evaluate different methods for the determination of amygdalin and the total cyanide content in different matrices and to develop a rapid test for quantification of the total cyanide content in stone fruit kernels and their products.

A further purpose is to discuss the options, challenges and dangers of utilizing stone fruit kernels, including a discussion on methods of detoxification.



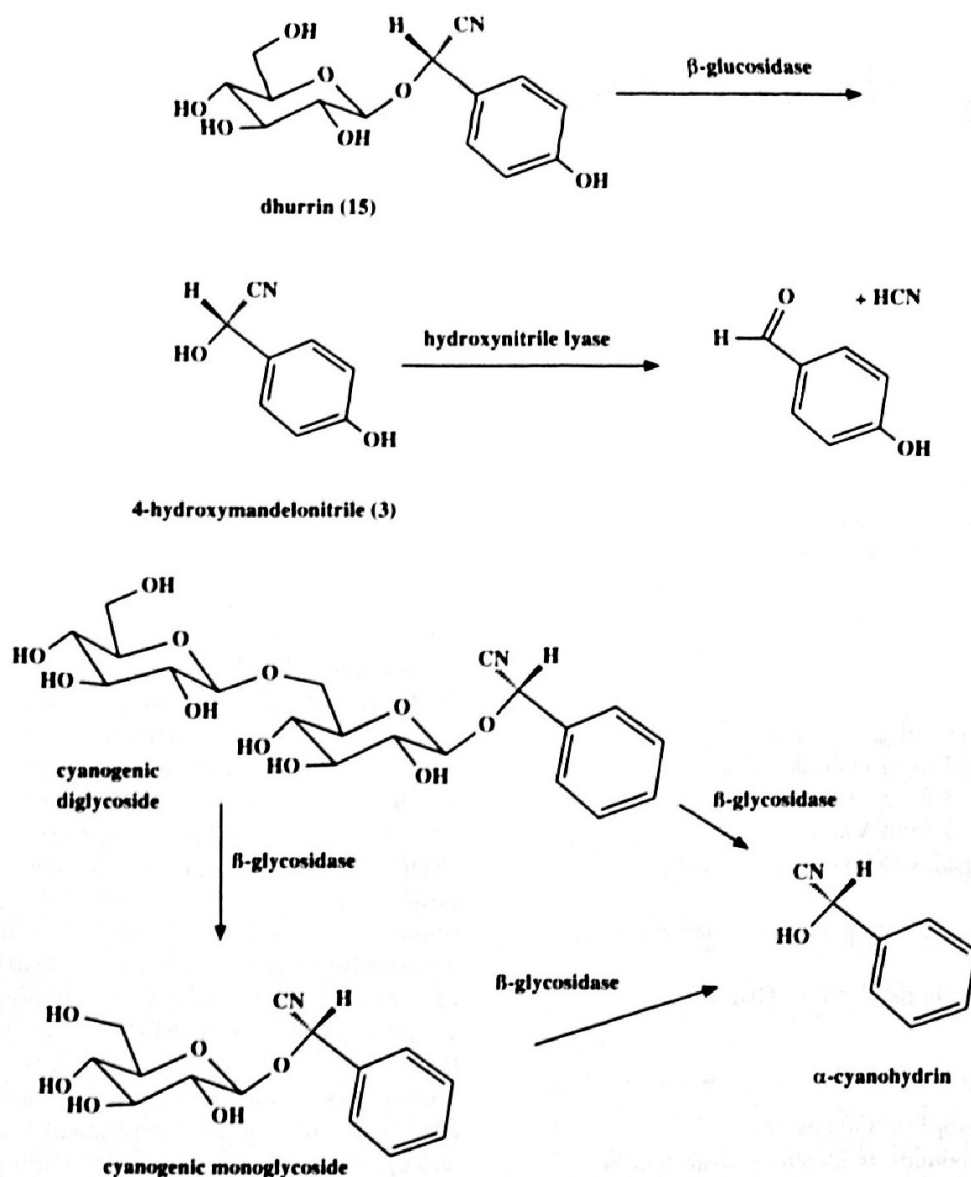
## 2. Principles

### 2.1 Cyanogenic glycosides and cyanogenesis

#### 2.1.1 General

Hydrogen cyanide (HCN) formation in plants has been known since ancient ages. In ancient Egypt, traitorous priests in Memphis and Thebes were poisoned to death with kernels of peaches (4) (5). In 1802, the pharmacist Bohm detected liberated HCN by distillation of bitter almonds (4) (6). In 1830, Robiquet and Boutron-Chalard discovered the structure of the cyanogenic compound in bitter almonds (4) (6). It was named amygdalin because the compound was isolated from *Prunus amygdalus* (synonym for *Prunus dulcis* or almond). Amygdalin has been found in many different seeds of other members of the Rosaceae like in apples (*Malus* spp.), peaches (*Prunus persica*), apricots (*Prunus armeniaca*), black cherries (*Prunus serotina*), and plums (*Prunus* spp.) (7) (8) (9) (10) (11) (12) (13) (14). The diglucoside amygdalin was the first cyanogenic glucosides which was isolated. Cyanogenic glucosides are present in at least 2650 species from more than 550 genera, and 130 families (15) (16), including many important crop plants (17) (18). After destruction of plant tissue containing cyanogenic glucosides, these are hydrolyzed by beta-glucosidases to glucose, an aldehyde or ketone, and HCN. This two-component system, of which each of the separate components is chemically inert, provides plants with an immediate chemical defence against attacking herbivores and pathogens (19) (20) (21) (22) (23) (24) (25) (26). Besides their possible defence function, accumulation of cyanogenic glucosides in certain angiosperm seeds may act as a storage deposit of reduced nitrogen and sugar for the developing seedlings (27) (28) (29) (11). Cyanogenic glycosides are the most common known forms of bound hydrocyanic acid. Besides cyanogenic glycosides, cyanolipids are O-beta-glycosided alpha-hydroxynitriles (cyanhydrines), which occur mainly in plants and in some insects (30).

Cyanogenic Glycosides and Cyanolipids



The most published compounds are glycosides of  $\alpha$ -hydroxynitriles or cyanohydrines and a few cyanogenic lipids. The glycosides are usually accompanied by a  $\beta$ -glucosidase enzyme which can produce the corresponding cyanohydrine (aglycon) and sugar. A second enzyme, the hydroxynitrile lyase catalyzes the dissociation of the cyanohydrine to a carbonyl compound and hydrogen cyanide (16) (Figure 2.1). Usually the substrate and the enzymes are stored in different compartments within the plant cell, therefore cyanide release does not occur without damage of the plant (31) (32). **Figure 2.1:**  $\beta$ -glucosidase produces the corresponding cyanohydrine (aglycon) and sugar. Hydroxynitrilelyase catalyses the dissociation of the cyanohydrine to a carbonyl compound and hydrogen cyanide (16).

The production of cyanide in many plants is extremely variable. Nevertheless, the distribution of cyanogenesis by cyanogenic glycosides is of systematic interest because certain structural types of cyanogenic glycoside are associated with specific groups of plants (15) (16)(33).

Cyanogenic glycosides are classified by their biogenetic precursors. These are the proteinogenic amino acids L-valine, L-isoleucine, L-leucine, L-phenylalanine and L-tyrosine. Furthermore the non-proteinogenic amino acid (2-cyclopentyl)-glycin works as precursor (34) for some cyanogenic glycosides such as deidaclin (35) and probably niacin as precursor of acalyphin (30) (36).

Cyanogenic glycosides are found in fern, gymnosperms and angiosperms. In ferns only compounds of phenylalanine-derived types were detected, in gymnosperms only taxiphyllin which is a cyanogenic glycoside derived of tyrosine. Angiosperms show a vast spread of cyanogenic glycosides. In monocotyledons the tyrosine-derived types are dominant whereas in dicotyledons almost all known cyanogenic glycosides are found. Currently more than 62 cyanogenic compounds are known (15)(35).

Hydrocyanic acid can be bound in form of cyanolipids by the family of sapindaceae and hippocastanaceae. In cyanolipids  $\alpha$ -hydroxynitrile is bound as ester with one or two, mostly C18:1 or C18:2 fatty acids (35).

In almost every plant, cyanogenic or non-cyanogenic, it is possible to detect small amounts of free hydrogenic acid. This free HCN is mainly a by-product of ethylene production and is not based on cyanogenesis and therefore should not to be perceived as cyanogenic processes (35).

Respectively to the biological and ecological meaning of cyanogenic glycosides in plants the function as defence mechanism against herbivore is to be noted(37). High concentrations of cyanogenic glycosides are found especially in organs of reproduction (flower, fruit, and seed) and in young leaves, so those parts of plants that need most protection due to their function and their stage of development. These facts attest to the thesis of a defensive role of cyanogenesis (30).

Cyanogenesis in agricultural plants such as cassava (*Manihot esculenta*, Euphorbiaceae) is of toxicological relevance for human nutrition (38) (39). After intake of cyanogenic glycosides, freed hydrocyanic acid acts neurotoxically. By degenerating peripheral neurons, damages of the nervus opticus and dyskinesia of extremities can occur (35) (30) (40).

Thiocyanate formed from cyanide inhibits the production of the thyroid hormone thyroxine and can lead to formation of goiters. Pharmaceutical products that contain cyanogenic glycosides (e.g. Laetrile ®) are not permitted in the European Union (35).

### **2.1.2 Biosynthesis**

Cyanogenic glycosides are secondary plant compounds that occur vastly in many plants. They release HCN which can make the plant poisonous if eaten. The enzymes responsible for production of the HCN have been known for long.

The aglycone portion of cyanogenic compounds is derived from amino acids. Most cyanogenic compounds come from a relatively small number of precursors: L-tyrosine, L-phenylalanine, valine, isoleucine, and L-leucine. Acalyphin appears to be derived from nicotinic acid. One series of cyanogens has aglycones that contain a cyclopentenoid ring and are derived from the non-protein amino acid, (2-cyclopentenyl)glycine (16) (41) (30).By double labelling experiments it has been demonstrated that the C-N bond is not broken during the biosynthetic process. All intermediates in the pathway contain

nitrogen. (16)(42). Major intermediates include a hydroxyl amino acid, aldoxime, nitrile, and a  $\alpha$ -hydroxynitrile (16) (43) (44). These intermediates are observed only at extremely low levels in the plants that contain them and that the proposed intermediates were incorporated at very different and inconsistent rates. These differences in rates were inconsistent with the order of incorporation of the different intermediates. A channelled process has been proposed in which the compounds are not liberated from the enzyme surface (16)(31). Channelling provides for the rapid and efficient flow of carbon and nitrogen atoms and at the same time perhaps protects labile intermediates from wasteful side reactions (16)(31).

$\beta$ -Glucosyltransferases have been isolated and purified from a few cyanogenic species. They have pH-optima from 6.5-9.0 and usually lack a requirement for metal ions or cofactors. Although they have an absolute specificity for UDP-glucose, they are less specific toward cyanohydrins (16)(45).

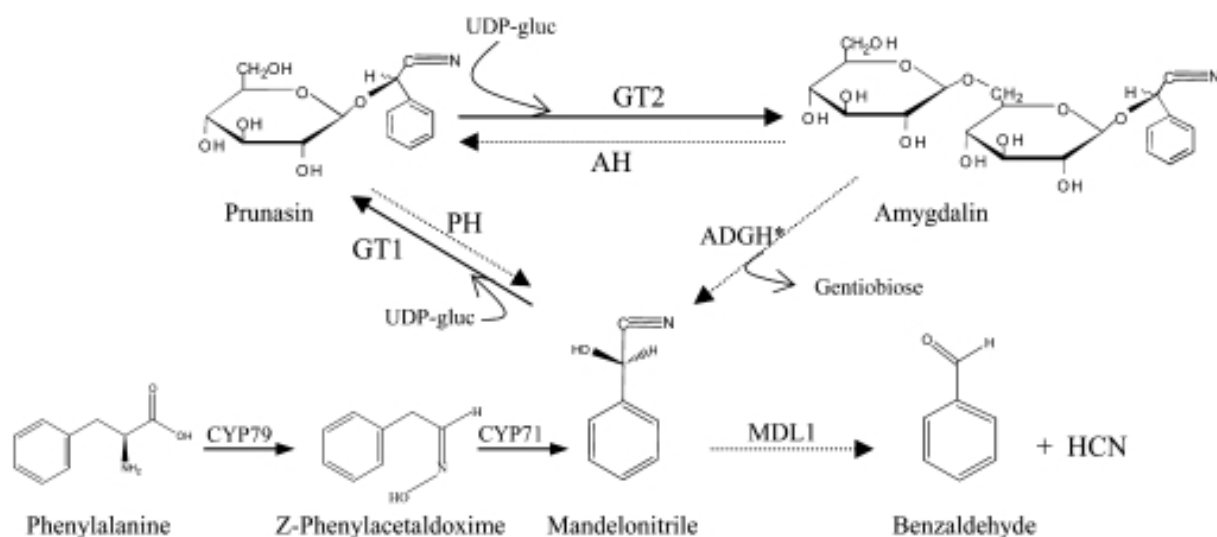
Precursor	Cyanogenic Glycosides (examples)
L-phenylalanine	<u>Diglycosides:</u> (R)-amygdalin, (R)-sucumin, (S)-epilucumin, (R)-vicianin, grayanin (46) <u>Monoglucosides:</u> (R)-prunasin, prunasin-6-malonate (47)
L-valine and L-isoleucine	linamarin, (R)-lotaustarin, (S)-epilotaustralin, linustatin
L-leucine	(S)-proacacipetalin, (R)-epiproacacipetalin, cyanolipids
L-tyrosine	(S)-dhurrin, (R)-taxiphyllin, (S)-heterodendrin
(2-cyclopentenyl)glycin	deidaclin, tertraphyllin A and B, volkenin, taraktophyllin
Niacin	scalyphin (probably)

**Table 2.1.:** Some cyanogenic compounds and their precursors (16)

### Biosynthesis of dhurrin and amygdalin

Studies in almonds have shown that prunasin is transformed into amygdalin during fruit ripening (9). Prunasin is present in roots, leaves, and kernels of sweet and bitter varieties (14). By tracer experiments it has been demonstrated that prunasin is synthesized from phenylalanine (48). Sorghum (*Sorghum bicolor*) contains the tyrosine-derived cyanogenic glucoside dhurrin (49) (45). Dhurrin biosynthesis is catalyzed by the multifunctional and membrane-bound enzymes cytochrome P450 (Cyt P450), CYP79A1 and CYP71E1 (50) (51) (52) (53). CYP79A1 catalyzes the conversion of tyrosine into Z-p-hydroxyphenylacetaldoxime (51) and CYP71E1 catalyzes the conversion of the Z-p-hydroxyphenylacetaldoxime into p-hydroxymandelonitrile (54) (52). Conversion of the

labile cyanohydrin into dhurrin is catalyzed by the soluble enzyme UDP-Glc (UDPG)-glucosyltransferase UGT85B1 (55) (56) (Figure 2.2). The entire pathway for dhurrin synthesis has been transferred from sorghum to arabidopsis (*Arabidopsis thaliana*) using genetic engineering (57) (58). Prunasin biosynthesis is assumed to follow the same biosynthetic scheme as dhurrin biosynthesis but no enzymes or genes involved have been identified yet (10). The monoglycoside prunasin is converted into the diglycoside amygdalin by an additional UDPG-glucosyltransferase (Fig. 2.1). In contrast to the biosynthetic enzymes in almond, the enzymes and genes involved in amygdalin degradation have been identified and characterized. The first step in amygdalin degradation is catalysed by the  $\beta$ -glucosidase amygdalin hydrolase (EC 3.2.1.117) and results in the formation of prunasin and glucose. Prunasin is subsequently hydrolyzed by prunasin hydrolase (EC 3.2.1.21), another  $\beta$ -glucosidase to form mandelonitrile and glucose. Mandelonitrile then is converted into benzaldehyde and HCN by mandelonitrile lyase (EC 4.1.2.10; (59). This conversion may also proceed non-enzymatically at neutral or alkaline pH. HCN inhibits cell respiration and is detoxified by  $\beta$ -cyano-Ala synthase (CASase), which converts HCN and cysteine into b-cyano-alanine (60).  $\beta$ -Cyano-alanine is converted into asparagine and aspartic acid by nitrilases (4)(61) (62) (63) (64) (65).



**Figure 2.2:** The metabolic pathways for synthesis and catabolism of the cyanogenic glucosides prunasin and amygdalin in almonds. Biosynthetic enzymes (black lines) are: CYP79 and CYP71, Cyt P450 monooxygenases; GT1, UDPG-mandelonitrile glucosyltransferase; and GT2, UDPG-prunasin glucosyltransferase. Catabolic enzymes (dashed lines) are: AH, amygdalin hydrolase; PH, prunasin hydrolase; MDL1, mandelonitrile lyase; and ADGH\*, amygdalin diglycosidase (putative). (4)

### 2.1.3 Occurrence

Cyanogenic compounds are found in all major plant groups. The distribution of cyanogenic compounds has been reviewed (33) (66) (67) (68). In families Araceae, Asteraceae, Euphorbiaceae, Fabaceae (69), Flacourtiaceae, Malesherbiaceae, Papaveraceae, Passifloraceae, Poaceae, Proteaceae, Ranunculaceae, Rosaceae, Sapindaceae and Turnerceae cyanogenesis is most common (16).

There is much variation from plant to plant in concentration of cyanogenic glycosides and  $\beta$ -glucosidases necessary to hydrolyze them. In a number of taxa only 1-3% of the individuals will have positive cyanogenic test results, in others all individuals are cyanogenic (16)(70).

In some genera, almost all tested species are cyanogenic. Only a few species of the genera *Prunus* (Rosaceae) or *Passiflora* (Passifloraceae) are not cyanogenic. In some other families and genera, only a single species is cyanogenic (15) (16).

Cyanogenic glycosides derived from L-phenylalanine, such as amygdalin, are found primarily in Rosidae and Asteridae. The compound best known is amygdalin, which is widespread in seeds of members of the Rosaceae such as apples, peaches, cherries and apricots (16).

Although it has been thought previously, that the Rosaceae are relatively homogeneous with regard to cyanogenesis and that the major compounds are derived from phenylalanine, this appears now to be true only for the subfamilies Maloideae and Amygdaloideae. Other members of the family contain compounds derived from other precursors such as the p-hydroxybenzoate and p-hydroxycinnamate of (S)-cardiospermin and dhurrin (16).

#### **2.1.4 $\beta$ -Glucosidases**

In most plants cyanogenic glycosides are accompanied by a corresponding  $\beta$ -glycosidase. One such enzyme system, emulsine from almond seeds, has fairly broad specificity and has been studied widely. Most of these enzymes have more specific substrate requirements. The specificity of enzymes from plants containing cyclopentenoid cyanogenic glycosides has been reviewed (71).

Also the activity of  $\beta$ -glycosidase can differ from plants containing diglycosides. E.g. the enzymes from *Davallia trichomaoides* and *Vicia angustifolia* hydrolyze (R)-viciantin and (R)-amygdalin at the aglycone-disaccharide bond, and the enzymes of *Prunin serotina* and *Linum usitatissimum* involve a stepwise removal of the sugars (72).

In some instances, when an unnatural enzyme is added to a substrate before the natural enzyme, no reaction is observed. The nature of these effects is dependent on concentrations of enzymes and substrates as well as the order of addition. Interactions of this type for cyclopentenoid cyanogenic glycosides and the corresponding enzyme system have been reviewed (71).

#### **2.1.5 Toxicity**

Cyanide poisoning occurs when a living organism is exposed to a compound that produces cyanide ions. The toxicity of cyanogenic glycosides is caused by the release of free hydrogen cyanide when they are decomposed. The cyanide ion halts cellular respiration by inhibiting the enzyme cytochrome c oxidase (EC 1.9.3.1) in the mitochondria (Figure 2.3).

The Scientific Panel on Food Additives, Flavourings, Processing Aids and Materials in Contact with Food (AFC) noted that cyanogenic glycosides present in plants, as sources of hydrocyanic acid, are relatively nontoxic until HCN is released. This can occur as a result of enzymatic hydrolysis by  $\beta$ -glucosidases following maceration of plant tissue, or

by the gut microflora. Depending on the specific glycosides the hydrolysis products can be, besides sugar moieties and HCN, benzaldehyde (for amygdalin, prunasin, sambunigrin,), phydroxybenzaldehyde (for dhurrin) and acetone (for linamarin). The potential toxicity of a cyanogenic plant depends primarily on its capacity to produce HCN (73). In summary the Panel noted further that:

1. Following oral administration, HCN is readily absorbed and rapidly distributed in the body via the blood.
2. HCN absorbed from the gut is metabolically converted to the less toxic thiocyanate. Other detoxification pathways include combination with vitamin B12 or some sulphur-containing amino acids. Acute toxicity results when the rate of absorption of HCN is such that the metabolic detoxification capacity of the body is exceeded.
3. Cases of human intoxication and chronic neurological effects have occurred from the ingestion of processed plants. This is particularly apparent when processing practices change as a result of trading practices or uncertain food supply.
4. The cyanide ion inhibits enzymes associated with cellular oxidation and causes death through energy deprivation. The symptoms, which occur within a few minutes, may include constriction of the throat, nausea, vomiting, giddiness, headache, palpitations, hyperpnoea then dyspnoea, bradycardia, unconsciousness and violent convulsions, followed by death.
5. The occurrence of intoxication symptoms depends upon the rapidity of the increase in HCN concentration in the tissues. In the case of cyanogenic glycosides, the route of exposure, the nature of the cyanogenic compound, the dose, and the ability of the organism to detoxify cyanide determine the symptoms.
6. The available toxicity data show that cyanogenic glycosides from certain plants could produce acute toxic effects. Thus fatalities have occurred from e.g. consumption of stone fruit kernels.
7. The chronic uptake of HCN, in sub-acutely toxic doses, may be involved in the pathogenesis of certain conditions including disturbance of thyroid function and neuropathies. The thyrotoxic effects of cyanide depend on its conversion to the iodine antagonist, thiocyanate.
8. Human cassava-eating populations showed ophthalmological and neurological symptoms which are associated with exposure to HCN, though it is likely that other nutritional or metabolic deficiencies affecting the cyanide detoxification mechanism are also involved (e.g. sulphate and zinc deficiencies).
9. Several epidemiological studies in cassava-eating populations, which established an association between cyanide exposure and spastic paraparesis, amblyopia ataxia or tropical ataxia neuropathy (TAN) and possibly goitre have also been considered. However, the data are highly confounded by other nutritional and environmental factors. Adequate long-term toxicity studies in animals fed a diet containing HCN or cyanogenic glycosides are also lacking.
10. Limited data from the UK show that the average and high (97.5th percentile) daily intake of HCN from its use in flavours or flavour ingredients were 46 and 214  $\mu\text{g}/\text{person}$ , which correspond to approximately 0.8 and 3.6  $\mu\text{g}/\text{kg bw}/\text{day}$  respectively. Data from a Norwegian dietary survey show that the average and high (97.5th percentile) daily

intake of HCN among consumers amounts to respectively 95 and 372 µg/person or 1.4 and 5.4 µg/kg bw/day. Cassava flour is used as a staple food mainly outside Europe; a consumption of 200 g/person would lead to an estimated intake level of 30 µg HCN/kg bw for a 60 kg adult. In accordance with the JECFA view such an intake would not be associated with acute toxicity. The highest level of HCN found in retail marzipan paste is 20 mg HCN/kg. Assuming on one sitting a person of 60 kg consumes 100 g marzipan containing such a level, that intake would be equivalent to 2 mg HCN or to 0.03 mg/kg bw.

The Panel concluded that the current exposure to cyanide from flavouring ingredients (97.5th percentile) is unlikely to give rise to acute toxicity. For chronic exposure the overall data were not considered adequate to establish a numerical no-observed-adverse-effect level (NOAEL) or Tolerable Daily Intake (TDI) in humans. In view of the lack of adequate data on chronic toxicity, the Panel supports the continued application of limits for the presence of HCN in foods and beverages (73).

#### **2.5.1.1 Absorption, distribution and excretion**

Absorption of cyanide occurs across both mucous membranes and intact skin (74). The most common inorganic cyanides are readily absorbed through the stomach and duodenum. Absorption by the gastrointestinal mucosa is dependent on the pH of the gut and the lipid solubility of the specific cyanide compound (75). Cyanides are rapidly distributed to all organs and tissues via the blood. The cyanide concentration is higher in red blood cells than in plasma by a factor of two or three, reflecting cyanide's tendency to bind to methaemoglobin. Cyanide may also accumulate in body cells by binding to metalloproteins or enzymes such as catalase or cytochrome c oxidase (74). Cyanide levels in a woman who died 30 minutes after ingesting 2.5 g NaCN were highest (up to 3.2 mg% [3.2 mg/100 g]) in the stomach contents, brain and urine (76). Two other studies found the concentration of cyanide to range from 0.2 to 2 mg% in the liver, kidneys and brain of poisoned humans (77) (78). It has been reported that small but significant levels of cyanide are present in normal, healthy human organs at concentrations of ≤0.5 mg/kg (as CN<sup>-</sup>), owing to the breakdown of cyanogenic foods and tobacco smoke by bacterial action and vitamin B12 (79). Cyanide is rapidly detoxified in the body by conversion to the much less toxic thiocyanate (CNS) ion. (80). The major pathway for this conversion is via the intramitochondrial enzyme rhodanase, a liver enzyme that catalyses the transfer of sulphur from a donor to cyanide to form thiocyanate (75) (81). Urine has been found to be the major route of excretion of thiocyanate. Average urinary excretion of thiocyanate normally ranges between 0.85 and 14 mg over a 24-hour period (75). Some cyanide is metabolized directly, and carbon dioxide is eliminated in expired air. A small amount of HCN is also eliminated in expired air (81).

#### **2.5.1.2 Toxic Effects**

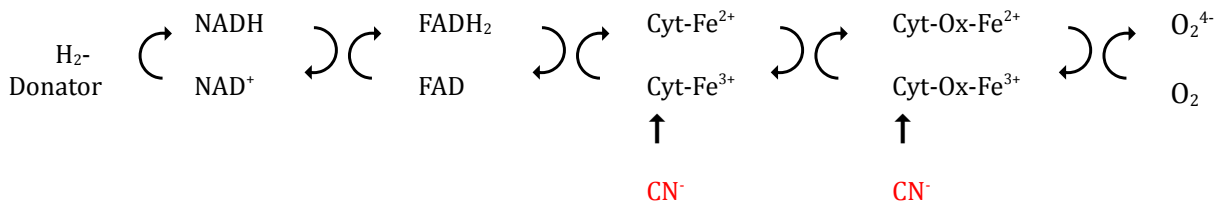
Cyanide is highly lethal to humans; lethal oral doses of cyanide compounds generally range from 50 to 200 mg CN (0.7 to 2.9 mg/kg bodyweight) (82); based on case reports of poisonings, an average fatal dose of cyanide has been estimated to be 1.52 mg/kg



bodyweight (83). In a two-year chronic toxicity study in which male and female rats were fed cyanide at doses as high as 7.5 and 10.8 mg/kg bodyweight per day, respectively, no clinical or histopathological effects of any kind were observed (84). Cyanide acts through the inhibition of cytochrome c oxidase in the respiratory electron transport chain of the mitochondria, impairing both oxidative metabolism and the associated process of oxidative phosphorylation (85) (86). Surveys in African communities where cassava is a staple crop show a strong correlation between cassava consumption and endemic goiter and cretinism. Dietary deficiencies, especially low intake of iodine, may contribute to these effects (87) (88).

**2.1.5.3 Mechanism**

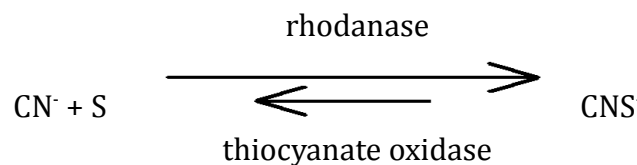
Cyanide has a high complex affinity to certain heavy metals. It blocks Fe(III) (not Fe(II)!) in cellular respiration enzymes of warm-blooded organisms. The respiratory chain is blocked at the stage of cytochrome oxidase Fe<sup>3+</sup> and therefore inhibits the activation of oxygen for further oxidation processes. The complexation is completely reversible (89).



**Figure 2.3:** Interaction of cyanide in the respiration chain (simplified). Blockage of cytochrome oxidase at oxidation stage 3 (89).

**2.1.5.4 Detoxification**

Cyanide is detoxified by rhodanase. This enzyme is present in various different types of tissue in warm-blooded organisms, especially in the liver. It binds cyanide to sulphur under formation of the less toxic thiocyanate (ger.: Rhodanid): The reaction is reversed by thiocyanate oxidase. In organisms the equilibrium is on the side of thiocyanate.



**Figure 2.4.:** Cyanide is detoxified by the enzyme rhodanase. The reaction is reversed by thiocyanate oxidase. In organisms the equilibrium is on the side of thiocyanate.

Velocity of detoxification is high: about 1mg/kg/h from animal experiment; about 0.1mg/kg/h from human after intake of sodium nitroprusside for therapeutic purpose. The lethal dose is considered to be 1mg/kg body weight CN<sup>-</sup>, the minimal lethal dose

therefore is detoxified within 1-10 hours. The limiting detoxification step is the mobilization of sulphur in the intermediate metabolism. The capacity of detoxification can be increased remarkable by intake of mobile sulphur, e.g. as sodium thiosulfate  $\text{Na}_2\text{S}_2\text{O}_3$ . Hydrogen cyanide and other cyanides do not tend to cumulate.

### 2.1.5.5 Symptoms of poisoning

The weak acid hydrogen cyanide is dissociated only to 1.6% at  $\text{pH} = 7.4$ . and therefore diffuses through cell membranes very easily. The blockade of cytochrome oxidase by cyanide is very fast. After inhalation first resorptive symptoms can occur after a few seconds. After ingestion of inorganic salts, hydrogen cyanide is formed by stomach hydrogen chloride, released and absorbed by the venae portae circulation.

### 2.1.5.6 Treatment

The treatment of cyanide intoxications is aimed on accelerating the body's own detoxification and on complexation of cyanide with other heavy metal containing structures.

- 1) Sodium-Thiosulfate ( $\text{Na}_2\text{S}_2\text{O}_3$ ): to supply sulphur for enzymatic formation of thiocyanate. (10% sol.; 10-20mL every 10 minutes)
- 2) Formation of methemoglobin: Fe(III) in methemoglobin binds to cyanide, though with a lower affinity than cytochrome oxidase. (Inhalation of amyl nitrite).
- 3) Cobalt compounds: Cyanide binds to hexadentical Co-compounds as  $\text{Co}_2\text{EDTA}$  or cobalamin (vitamin B12) (89).

## 2.1.6 Physical and chemical properties of stone fruit kernels

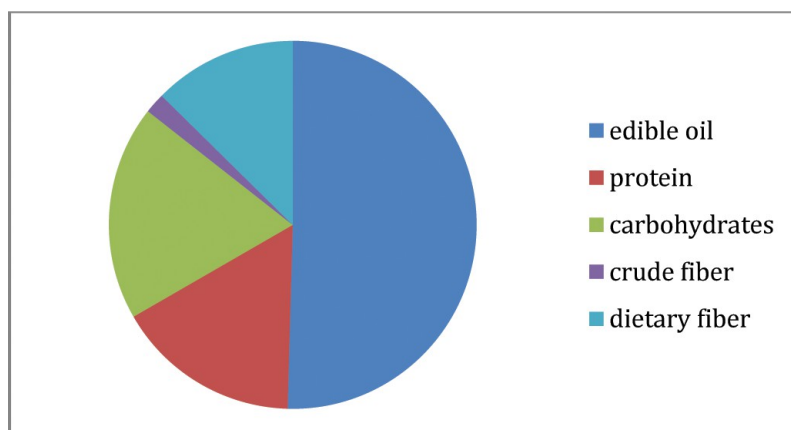
### 2.1.6.1 Physical and chemical properties of apricot kernels

The percentage of the kernel in the pit of apricot varies from 18.8 to 38.0%, calculated as  $[(\text{kernel})/(\text{pits} + \text{kernels})] \times 100$  (1) (90) (91) (92) (93) (94) (95) (96)(97).

Some average dimensions of apricot kernels are listed here:

length, 14.0–19.17 mm; width, 9.99–10.20 mm; thickness, 3.3–6.27 mm; geometric mean diameter, 9.89–10.31 mm; and mass, 0.47–0.48 g (90) (95) (98) (99). The 100-kernel weight range is 28.7–65.1 g (1)(94) (95)(100).

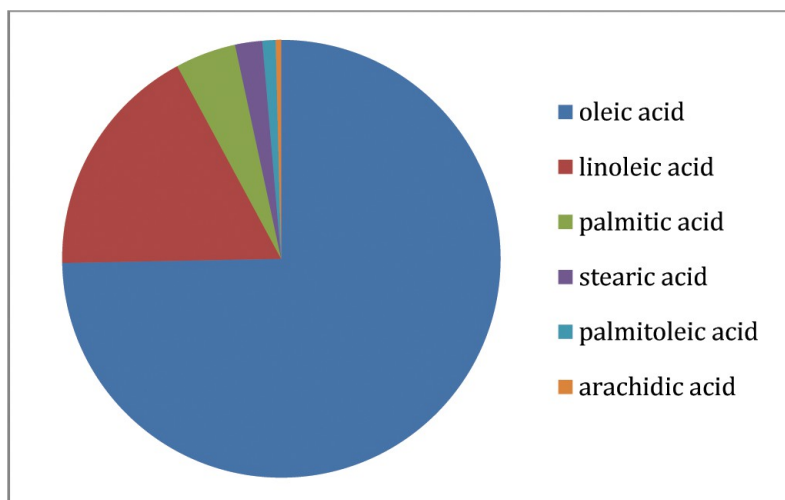
Apricot kernels contain 48-54% oil, 18-23% protein, 21-35% carbohydrates, 0,8-4,7% crude fiber and 6-22% dietary fiber (101) (102).



**Figure 2.5 .:** Chemical composition of apricot kernels

The fatty acid composition of apricot kernel oil is:

Oleic acid: 75%; linoleic acid: 17,5%; palmitic acid: 4,5%; stearic acid: 2%; palmitoleic acid: 0,6-0,9%; arachidic acid: <0,4% and small amounts of eicosenoic acid (101) (102).



**Figure 2.6.:** Fatty acid composition of apricot kernel oil

The reported contents of unsaturated fatty acids are 91.5–91.8% and 7.2–8.3% of saturated fatty acids respectively (90), neutral lipids: 95.7–95.2%, glycolipids 1.3–1.8%, and phospholipids 2.0% (90). The kernel oil contains 11.8 mg/100 g campesterol, 9.8 mg/100 g stigmasterol, and 177.0 mg/100 g sitosterol (103).

The total and oil composition of other stone fruit kernels do not relevantly differ to each other. Different stone fruit kernels differ though in their tocopherole composition pattern. Apricot kernel oil e.g. has a relatively high concentration of  $\gamma$ -tocopherole (22,4 mg/100g) and a small concentration of  $\alpha$ -tocopherole (0,5mg/100g) which makes it distinguishable from other stone fruit oils (104).

Reported protein content of apricot kernel are very variable and range from 14.1 to 45.3% (90) (91) (92) (94) (95) (105) (106) (107) (108). A PAGE study found that apricot kernel proteins contain 84.7% albumin, 7.65% globulin, 1.17% prolamin, and 3.54% glutelin. Nonprotein nitrogen is 1.17%, and other proteins are 1.85% (95)

Essential amino acids in apricot kernel constituted 32–34% (105) of the total amino acids. The major essential amino acids (mmol/100 g meal) were arginine (21.7–30.5) and leucine (16.2–21.6), and the predominant nonessential amino acid was glutamic acid (49.9–68.0) (92).

In vitro digestibility values of apricot kernel protein by a pepsin-pancreatin enzyme system are  $96.4 \pm 1.2 - 99.1 \pm 0.3$  % (95).

Carbohydrate content of apricot kernel was reported variously as 25.5% (w/w) (109), 17.3% (94), and 18.1–27.9% (92). The total sugar content was reported as 4.10% in undefatted kernel and 7.76% in defatted kernel (95).

The kernels contain thiamine, riboflavin, niacin, vitamin C (90),  $\alpha$ -tocopherole, and relatively high concentration of  $\delta$ -tocopherole (32.2 mg/100g) (103). The ranges for mineral content of apricot kernel (mg/100 g dry matter) were: Na, 35.2–36.8; K, 473–570; Ca, 1.8–2.4, Mg, 113–290; Fe, 2.14–2.82; Zn, 2.33–3.15 (90) (96) (110).

### 2.1.6.2 Chemical composition of sour cherry kernel oil

Popa et al. (111) reported that sour cherries kernel oil contain high levels of oleic acid (42.9 %), followed by linoleic acid (38.2 %), while the dominant saturated fatty acids were palmitic (11 %) and stearic acid (6.4%).

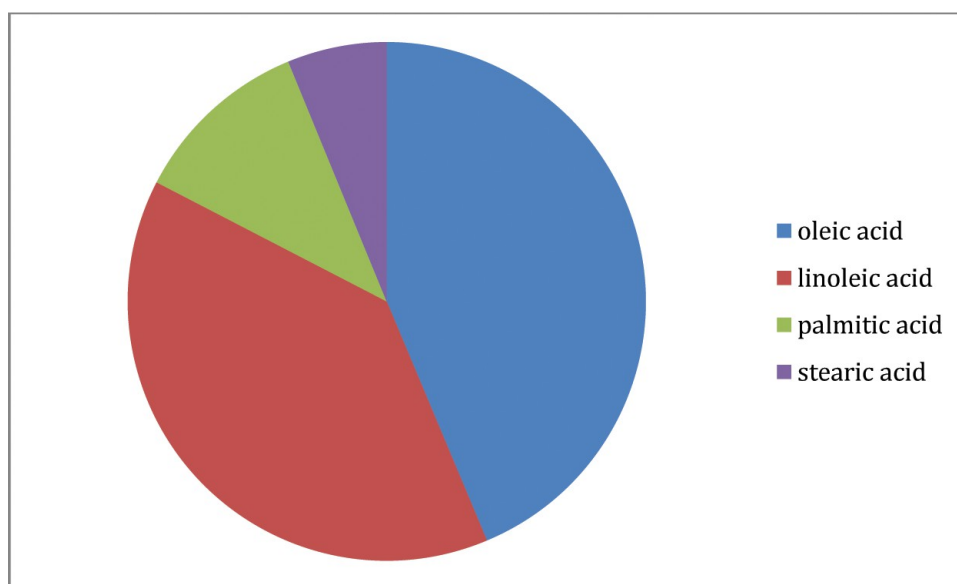


Figure 2.7.: Fatty acid composition of sour cherry oil

## 2.2 Determination of cyanogenic potential in stone fruit kernels and their products.

### 2.2.1 Norm method: determination of hydrocyanic acid in marzipan, persipan and their prestages by distillation and titration.

The norm method PV-33-HCN 2007-10 for determining hydrocyanic acid in marzipan, persipan and their pre-products is conducted by distillation and subsequent titration (112) (113).

### 2.2.2 Norm Method: Animal feeding stuffs — Determination of Hydrocyanic acid by HPLC

Cyanogenic glycosides are extracted with an acid solution. After incubation the pH is adjusted to neutral and  $\beta$ -glucosidase is added for enzymatic decomposition at 38°C. Then cyanide is extracted by steam distillation and collected in a potassium hydroxide solution. In order to obtain a fluorescent complex cyanide is derivatized with taurine and

NDA (2,3-Naphthalendicarboxyaldehyde). The cyanide complex then is analyzed with HPLC and fluorescence detection.

### **Range of application**

The norm method ÖNORM EN 16160:2010 is for determination of bound and free cyanide in animal feeding stuffs and animal feeding stuffs raw material of herbal source. The method is validated from 10 mg HCN/kg to 350 mg HCN/kg. If the method is applied outside this range it should be validated. A limit of quantification of 2 mg HCN/kg should be achieved usually (114).

### **2.2.3 Determination of cyanide content by chemical or enzymatic hydrolysis of the cyanogenic glycosides (CG) and quantification of cyanide.**

For qualitative or semi-quantitative determinations of cyanide, the easiest and most reliable method is a simple test with either Feigl-Anger or sodium picrate paper. The reactions on which these tests are based as well as other methods for detection of cyanogenic glycosides are described by Hegnauer (15).

Sodium picrate paper is prepared by dipping filter paper into an aqueous solution of 0.5% picric acid and 5% Na<sub>2</sub>CO<sub>3</sub>, then allowing the paper to dry. The paper may be stored dry but should be moistened just before use (16) (115) (116). The detection limit of picrate paper with plant samples is 0.001-0.002% HCN by weight, which corresponds to about 0.01-0.02% prunasin (15) (117).

Feigl-Anger paper is made by mixing equal volumes of solutions of tetrabase [4,4'-tetramethyldiaminodiphenyl-methane] and copper ethylacetoacetate (117) (118). Feigl-Anger paper is somewhat more sensitive than picrate paper (119).

These qualitative methods are very useful for screening large numbers of samples because they are simple, fairly specific, and require no equipment other than vials and corks. These qualitative methods also are useful for monitoring separations of cyanogenic compounds from TLC plates or chromatography paper during isolation and purification.

Methods for the quantification of cyanide in plant tissues involve hydrolysis of the cyanogenic glycosides and release of HCN, which is trapped in a basic solution and determined colourimetrically (117) by the method of Lambert et al. (1975) which can detect amounts of HCN of 5 ng and more (120).

Methods for the quantification of particular cyanogenic glycosides have been reviewed (121) (122)(123).

Emulsine, the β-glycosidase from almonds, has been used for many qualitative and quantitative cyanide determinations. This commercially available enzyme will hydrolyze several cyanogenic compounds (some very slowly), although it is inactive against others (32). This complex mixture of enzymes (β-glucosidase, [3-glucuronidase, sulfalase, and β-D-mannosidase) is also commercially available. This enzyme is active against a broad spectrum of cyanogenic glycosides. In contrast, most other β-glycosidases have relatively specific substrate requirements (71) (124) (125) (126) (127)(128).

### **2.2.4 Determination of amygdalin by chromatographic methods**

#### **2.2.4.1 Determination of amygdalin by high pressure liquid chromatography HPLC**

Chandra and Nair (129) reported a method for quantification of benzaldehyde and its precursors amygdalin and mandelonitrile in stone fruit kernels. In their work kernels

from Michigan-grown tart cherry *Prunus cerasus* L. cv. Montmorency were frozen at  $-40^{\circ}\text{C}$ , lyophilized, crushed and extracted sequentially with hexane and methanol. Amygdalin, mandelonitrile and benzaldehyde were found in the kernel extracts and were quantified by HPLC (C-18,  $\text{CH}_3\text{CN}:\text{H}_2\text{O}$  (70:30v/v) isocratic, 1.5mL/min, 210nm). The same method could be used to quantify benzaldehyde and precursors in a start product and to measure purity in the end product. (compare 2.5.2.2.4.)

Several different HPLC methods for extraction, including methods for inhibition of epimerisation and quantification of D-amygdalin and neoamygdalin were described by Ja-Yong Koo et al. (130), Joo, Woo-Sang et al. (131) and several others.

#### **2.2.4.2 Determination of amygdalin by gas chromatography GC/MS**

Due to the low vapor pressure of amygdalin it is determined by gas chromatography indirectly. Kawai et al (132) (133) reported a method for gas chromatographic enzymic determination of amygdalin. In this method, amygdalin is hydrolyzed by  $\beta$ -glucosidase. The liberated benzaldehyde is then converted by pentafluorobenzoyloxylamine to its o-pentafluorobenzyl oxime which then is determined by gas chromatography using a flame ionization or electron capture detector.

#### **2.2.4.3 Determination of amygdalin by micellar electrokinetic chromatography (MEKC)**

Chung et al (134) developed a simple, rapid and reproducible method for the determination of D-amygdalin and its epimer by using micellar electrokinetic chromatography (MEKC). Separation of D-amygdalin was performed in a 20 mM sodium borate buffer (pH 8.5) containing 300 mM sodium dodecyl sulphate using a bare fused-silica capillary. The eluates were monitored by the absorbance at 210 nm. The applied electric field was 278 V/cm, and the time needed for the separation of D-amygdalin did not exceed 6 min. The calibration curve for D-amygdalin showed excellent linearity in the concentration range of 5–500 mg/mL. The migration time and the corrected peak area show relative standard deviations ( $n=6$ ) of 0.86% and 1.48%, respectively. The limit of detection ( $S/N=3$ ) for D-amygdalin was 2 mg/mL. Under acidic and neutral conditions, amygdalin exists only as the D-form; however, under basic conditions, it shows both the D- and L-forms with a concentration ratio of 1:1.3 (D-amygdalin/ L-amygdalin). Results of HPLC, UV-Vis spectrophotometry, and mass spectrometry reconfirmed the identification of D-amygdalin and its epimer. The number of theoretical plates of D-amygdalin is about 100 000 in MEKC, which is significantly higher than  $\sim 8000$  of HPLC. This method has been successfully applied to the determination of amygdalin epimers in various apricot kernel extracts and pharmaceutical products (134).

#### **2.2.5 Determination of amygdalin by enzyme-immunoassay**

In this study New Zealand White rabbits were immunized with an amygdalin-KLH (keyhole limpet hemocyanin) conjugate and produced anti-sera reactive to amygdalin, proving that amygdalin can behave as a hapten in rabbits. Using this polyclonal antibody, a competition enzyme immunoassay for determination of amygdalin concentration in aqueous solutions was developed. This technique is able to effectively detect abnormally

high amygdalin content in various seeds and nuts. Enzyme immunoassay can be used to determine the amount of amygdalin in food extracts, which will allow automated analysis with high throughput (135).

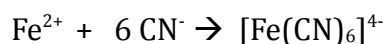
## 2.3 Decontamination methods

Caius Plinius Secundus (better known as Pliny the Elder) stated in his 37-volume encyclopaedia entitled *Naturalis Historia*, which was completed shortly after his death in 79AD, that the Romans were proud of knowing how to remove bitterness from almond kernels (Pliny the Elder, 77;Álvarez, 1798).

### 2.3.1 Decontamination by water

After blanching and peeling, almonds which contain the cyanogenic glycoside amygdalin (bitter almonds) are debittered by leaking with flowing water. The HCN content is reduced by 80% in 24h and the water content of the almond is raised to 38%. A prolongation of the process reduces the HCN content only minimally (104). Other stone fruit kernels can be decontaminated analogously. Experiments of debittering in batch process for less water consumption are described later. (3.2.1.)

Decontamination of the cyanide, benzaldehyde and amygdalin containing water used for debittering the kernels can be done by addition of Fe(II) ions, e.g. as FeSO<sub>4</sub> under formation of ferrocyanide:



The ferrocyanide can then be precipitated by addition of K<sup>+</sup> and Fe<sup>3+</sup>:



### 2.3.2 Decontamination with ethanol

Although ethanol is a much more expensive solvent, decontamination with this organic compound can be of interest in certain fields of food production: for amaretto production stone fruit kernels are leaked in ethanol/water solutions. Presumably there is a decontamination taking place during the process. Experiments of decontamination with ethanol are described later.

### 2.3.3 Decontamination by fermentation with β-glycosidase (autodecontamination)

By grinding cyanogenic parts of plants the vacuoles get damaged and amygdalin gets in contact to the corresponding enzymes and hydrocyanic acid is formed (16). The transient toxin then can be calcinated by exposure to heat.

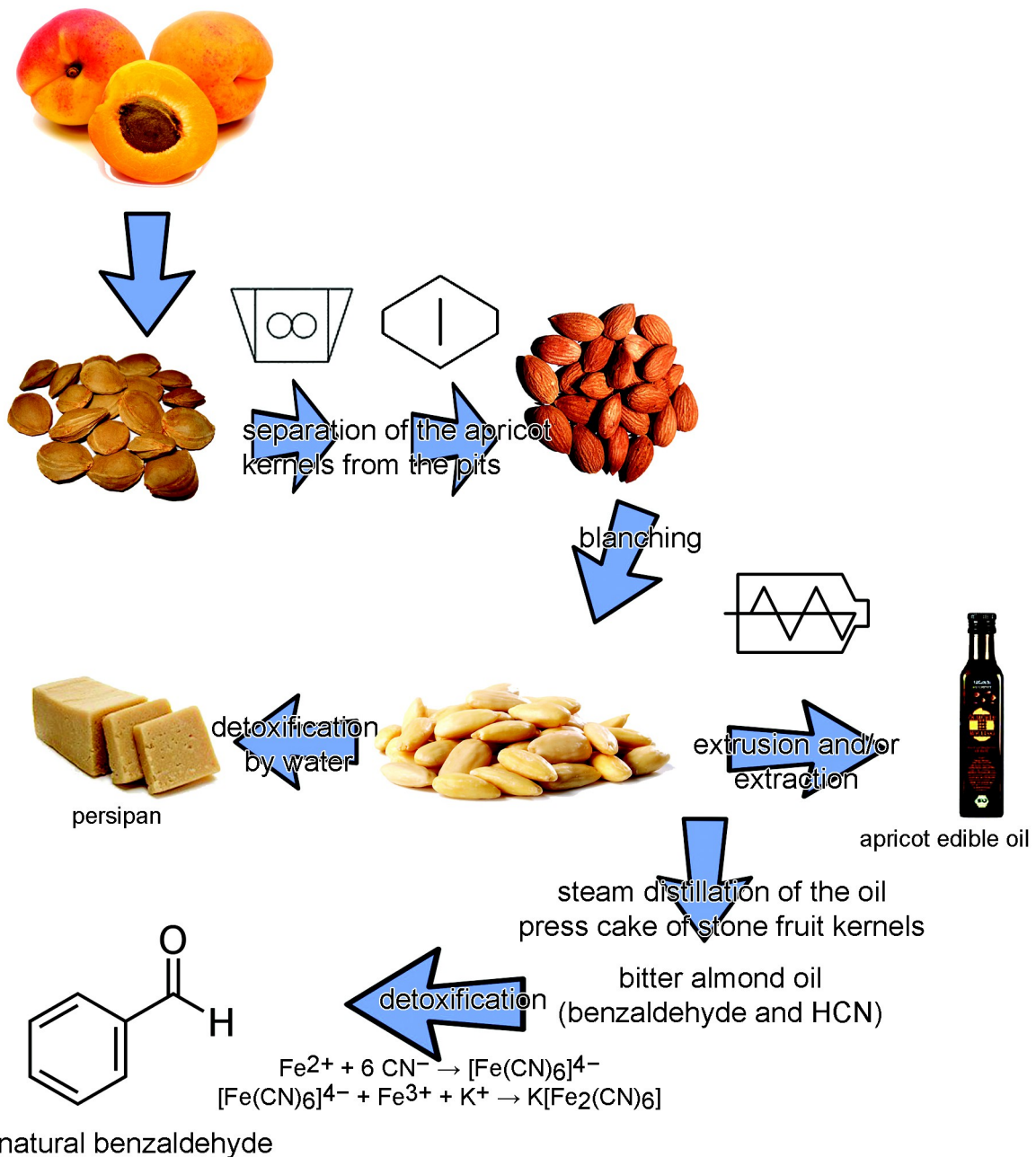
The traditional preparation of cyanogenic plants, such as cassava (*Manihot esculenta*), includes grinding and exposure to sunlight and air.

Experiments described later show that grinding and exposure to heat is not an effective method for decontamination of stone fruit kernels.

## 2.4 Processing options of stone-fruit kernels containing cyanogenic compounds

### 2.4.1 Overview

Figure 2.8 shows a brief overview of processing options of stone fruit kernels exemplified by apricot kernel processing.



**Figure 2.8.:** Processing options of apricot kernels containing cyanogenic compounds. (136).



The work of Gezer et al. (1) was aimed to study the work process and to determine the work capacity, work effectiveness, energy consumption and labour force requirements of basic units such as washing, sorting, breaking and separating units in an apricot pit breaking and separating plant. The study was carried out in an apricot pit processing plant, founded on a closed area of 300m<sup>2</sup> in Malatya, Turkey.

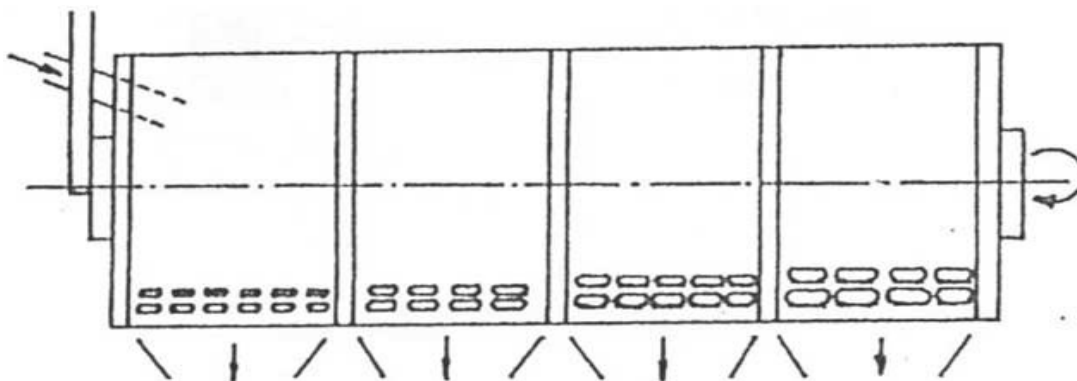
#### 2.4.1 Separation of the apricot kernels from the pits

Because of the many similar physical properties between kernels and outer parts of the apricot pits, their separation process could not be done effectively for many years and therefore it was necessary to do it manually.

The apricot pits are collected from farmers in sacks and are taken to the sorting units via conveyers after being washed. In the sorting unit they are classified in four size groups and then sent to the breaking unit. Broken pits are carried to separating units in sacks and there, kernels are separated from their shells. In order to improve the effectiveness of the separation process, the mixture is dried before entering to separating unit. This drying process can be natural or artificial. Natural drying is made by exposing the mixture to the sun for one day. In artificial drying, the mixture spread on the floor is exposed to fuel-heated air for 1 h.

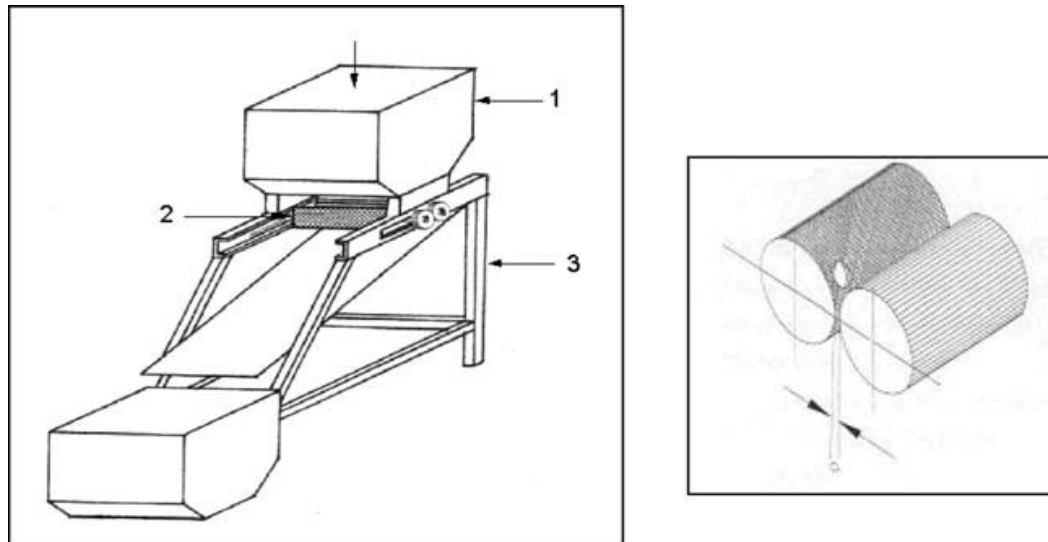
There is a semi-automated process cycle in the plant. The washing and sorting units work depending on each other. The connection between them is via helix conveyer. The breaking and separation units work independently from each other and other units. While transporting between the units, the products are stored in sacks which are made of polyester material with a capacity of 50 kg.

The sorting unit consists of four cylindrical rotating sieves. Its diameter is 0.65 m, its length is 6 m and its slope is 4%. The sieves have round holes and its first, second, third and fourth level holes are 9.5, 10.5, 11.5 and 12.5 mm in diameter, respectively (Fig. 2.5.1).



**Figure 2.9.:** The schematic perspective of sorting unit (1).

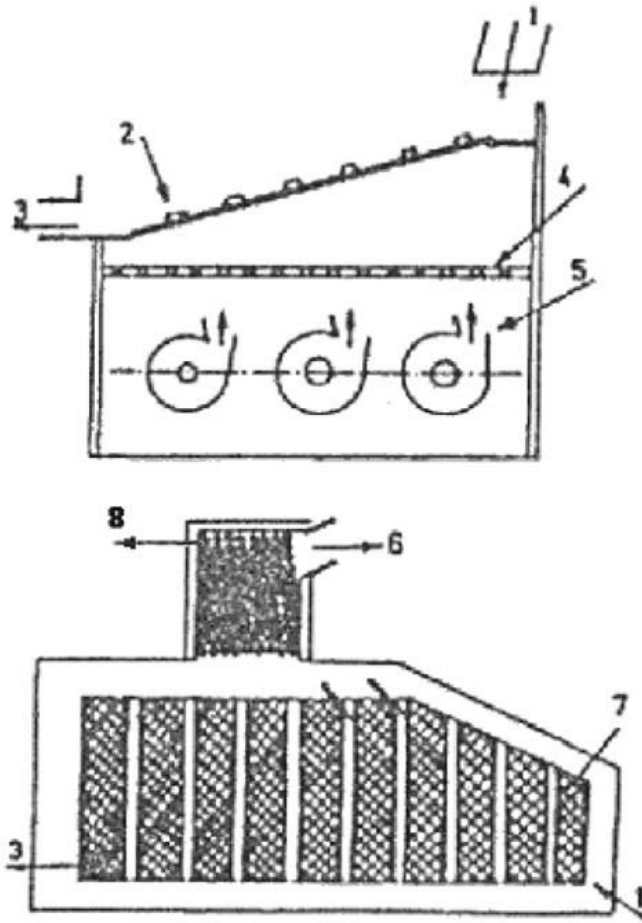
Basically, the breaking unit consists of two breaking rollers which are 100 mm in diameter, 500 mm in length. The distance between rollers can be adjusted for each size of pit. This unit works approximately at 200 turns/min (Fig. 2.5.2).



1. Reservoir 2. Breaking rollers 3. Chassis

**Figure 2.10.:** Apricot pit breaking unit (1).

The separation unit is manufactured by Ender Degirmen Makinaları in Mersin, inspired from an Italian model. It is a gravity table and successfully separates the kernels from their shells through their difference in specific gravity (Kernel density is  $1.05 \text{ g/cm}^3$ , the density of pit shell is  $1.19 \text{ g/cm}^3$ ). The gravity table is 1350 mm in width, 2800 mm in length and 1500 mm in height. With the effects of slope, air pressure and horizontal and vertical vibration; the mixture which is dropped onto table with many fine holes is separated with the lower dense kernels going to upper parts of the table and the more dense shells going to the lower parts of the table. Unbroken pits collected from unbroken pit sieve are sent to breaking unit for re-breaking. The separated kernels and the shells are sacked separately.



1. Entrance of mixture    2. Slowing beads    3. Exit of shell    4. Air spreading sieve  
 5. Air blowers    6. Exit of kernel    7. Sieve    8. Exit of unbroken pit

**Figure 2.11.:** Separating unit (1)

In both the breaking and the separation unit, the ratio of broken kernels was less than 1%. The work capacity (t/h), the work effectiveness (%), the energy consumption (kW/h) and the labour force requirements of the basic units in the plant – washing, sorting, breaking and separation – were determined and given in Table 2.5.1. As shown in Table 2.4.1, the mechanization shows the minimal energy consumption and the plant is working with an effectiveness of 99% for separating the kernels from their shells.

Basic parameters of washing, sorting, breaking and separating units

Units	Parameters			
	Work capacity (t/h)	Work effectiveness (%)	Energy consumption (kW/h)	Workforce requirement (worker)
Washing	1.5	–	3.96	1.0
Sorting	1.5	95	1.35	1.0
Breaking	2.0	95	2.34	1.0
Drying	1.0	–	–	3.0 <sup>a</sup>
Separation	1.6	99	12.77	2.0

<sup>a</sup> Drying process is undertaken by the workers of the other units of the plant while plant is not working.

**Table 2.2.:** Basic parameters of washing, sorting, breaking and separating units (1)

In all the working units, electrical motors are used. The number of workers in the plant is five. In the plant approximately 5 tonnes of apricot pits are handled each day and 1000 kg kernel is obtained.

Again in Malatya region, there is a plant with a daily capacity of 40 to 50 tonnes at 2% loss. However, bitter kernels are processed in this plant and washing process is not done. But, it must be considered that all these values may show differences depending on the type of apricot, whether its kernel is acrid or sweet, the quality of pits and adjustments and specifications of units.

These results show that the breaking and separating processes of apricot pits can be made possible and applicable by means of effective and efficient new methods and with lower energy consumption. However, the labour force requirement of the plant can be reduced by an automated continuous process cycle between sorting, breaking, drying and separating units.

In the plant, all machines must be compatible with each other in terms of work capacity. Drying process must be done by a dryer located between breaking and separating units. This can be done by exposing the mixture to the heated air coming from the upper apparatus to the moving platform on which the mixture is placed. For drying, this process will be enough since only the shell of the pits gets wet during the washing process.

## 2.4.2 Kernel processing

Due to the high cyanogenic potential, it is not possible to use unprocessed apricot kernels directly in foods. At least one step of detoxification is necessary.

### 2.4.2.1 Production of edible apricot oil

Apricot edible essential oil can be either obtained by extraction, hot pressing and cold pressing.

### 2.4.2.2 Production of natural benzaldehyde from stone fruit kernels

#### 2.4.2.2.1 Principles

Benzaldehyde is the simplest and industrially the most important aromatic aldehyde. It exists in nature, occurring in combined and uncombined forms in many plants. The best known source of benzaldehyde is amygdalin. The odour of bitter almonds and other stone fruit kernels arises from small amounts of free benzaldehyde formed by hydrolysis of amygdalin (137).

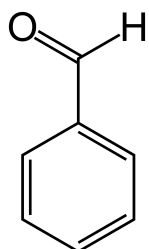


Figure 2.12.: Benzaldehyde [100-52-7], structure

#### **2.4.2.2.2 Production of natural benzaldehyde**

Zhao et al reported 2007 a patented method (138) to obtain natural benzaldehyde from apricot seeds. The method comprises boiling the apricot seeds for 3 min, peeling, cold pressing at  $\leq 60^{\circ}\text{C}$  to obtain defatted almond and almond fatty oil, porphyzizing the almond, screening, adding hydrochloric acid soln. (with  $\text{pH} = 5$ ), hydrolyzing, soaking at  $40^{\circ}\text{C}$  for 60 min, steam distillation for 60 min to obtain bitter almond essential oil containing cyanide, adding 1 mol/L caustic soda soln., 0.5 mol/L ferrous sulphate solution, and saturated lime water solution sequentially, allowing to react at  $30^{\circ}\text{C}$  for 10 min, and distilling to detoxify for obtaining the detoxified bitter almond essential oil with benzaldehyde content  $>90\%$  and cyanide content  $<0.5$  mg/kg.

##### **2.4.2.2.2.1 Recovery of wastewater containing benzaldehyde by simultaneous distillation-extraction (SDE)**

Pollien et al. (139) reported a method for recovery of flavours from wastewater. The by-product from the treatment of apricot kernels contained 178mg/kg natural benzaldehyde and non-volatiles (proteins). A recovery of 54% was achieved. (139)

##### **2.4.2.2.2.2 Base-catalysed production from natural cinnamaldehyde**

It is possible to obtain benzaldehyde from cinnamaldehyde. The product obtained by this method declaration as “natural” is not accepted in Europe as it is in the USA (140).

##### **2.4.2.2.2.3 Extraction by microwave**

Zhang et al (141) reported the microwave processing method of Semen Armeniacae Amarum (*Prunus armeniaca* var. *ansu*). The experimental results showed that amygdalase was completely inactivated and the contents of amygdaloside were not reduced at all (141).

##### **2.4.2.2.2.4 Quantification of benzaldehyde in the product.**

Chandra and Nair (129) reported a method for quantification of benzaldehyde and its precursors in stone fruit kernels. In their work kernels from Michigan-grown tart cherry *Prunus cerasus* L. cv. Montmorency were frozen at  $-40^{\circ}$ , lyophilized, crushed and extracted sequentially with hexane and methanol. Amygdalin, mandelonitrile and benzaldehyde were found in the kernel extracts and were quantified by HPLC (C-18,  $\text{CH}_3\text{CN}:\text{H}_2\text{O}$  (70:30 v/v) isocratic, 1.5mL/min, 210nm) (129). This method can be used to quantify benzaldehyde and precursors in a start product and to measure purity in the end product.

#### **2.4.2.3 Production of persipan**

Persipan is a cheaper substitute for marzipan produced from other stone fruit kernels than sweet almonds. The manufacturing is carried out analogously to the manufacturing of marzipan, only that the amygdalin and hydrocyanic acid has to be removed. This step is carried out by cold flowing water for 24 hours (104).

Experiments are described later where this process can be improved due to less water consumption.

#### **2.4.2.4 Antioxidant properties of roasted apricot kernel flours**

Durmaz and Alpaslan (100) evaluated the antioxidant properties of peeled, defatted and roasted apricot kernel flours by determining radical scavenging power (RSP), anti-lipid peroxidative activity (ALPA), reducing power (RP), total phenolic content (TPC), assessed by DPPH test, b-carotene bleaching method, iron (III to II) reducing test and Folin method, respectively. Browning degree of the samples were also measured and found to increase almost linearly with the roasting time. Contrary to browning degree, RSP, RP and TPC did not increase linearly but shows a maximum for 10 min of roasting at 150°C. Roasting reduced the ALPA values, thus unroasted sample showed the highest ALPA value. RSP, RP and TPC measurements of all samples, were in high correlation (at least,  $r = 0.92$ ).

#### **2.4.3 Processing kernels from other stone fruits**

Kernels from other stone fruits like peach, cherry, sour cherry, nectarine, etc. can be processed in similar ways. The results expected are similar products with little differences in odour, flavour and colour.

### 3. Materials

#### 3.1 Sample Materials

Sample	Type	Details
A	Sour cherry kernels	Harvested from a sour cherry tree in a private garden in Vienna, Austria. Year: 2009
B	Apricot kernels	<i>Wachauer Marille</i> from Obstgarten Reisinger, Mitterndorf am Jauerling 1, A-3620 Spitz an der Donau, Austria. Year: 2009
C	Apricot kernels	<i>Naturgarten Bio-Aprikosenkerne</i> , purchased at BIOWELT, Am Naschmarkt 326-33, Vienna, Austria. Year: 2009
D	Apricot kernels	Purchased open (without label in a plastic bag) at Am Naschmarkt 496, Vienna, Austria. Origin: Usbekistan. Year: 2009
E	Apricot kernels, roasted	<i>Wachauer Marille</i> , Wieser Geröstete Marillenkerne, purchased from MARKUS WIESER GMBH - ÖSTERREICH 3610 Weissenkirchen in der Wachau, Wösendorf 13, Austria Year: 2009
F	Bitter almonds	Naturgarten Bittermandeln, purchased at BIOWELT, Am Naschmarkt 326-331, Vienna Austria Origin: Usbekistan. Year: 2009
G	Sweet almonds	Purchased open (without label in a plastic bag) at Am Naschmarkt 613; Origin: Italy Year: 2009
H	Marzipan filling	Apricot marzipan filling from "Marillen-Duett" chocolate, contains apricot kernels, purchased at BIOWELT, Am Naschmarkt 326-331, Vienna Austria Year: 2009
I	Chocolate	"Marille mit Krokant", contains 4% apricot kernels, purchased at BIOWELT, Am Naschmarkt 326-331, Vienna, Austria. Year: 2009 Year: 2009
J	Persipan	Self made from apricot kernels from Obstgarten Reisinger, Mitterndorf am Jauerling 1, A-3620 Spitz an der Donau, Austria. Year: 2009

K	Cherry kernles	From <i>Kirschkernkissen (cherry stone cushion)</i> , purchased at Bipa, Erdbergerstraße 52-60, Vienna, Austria. Year: 2010
L	Flax seed	Purchased without label at Am Naschmarkt 496, Vienna, Austria Origin: Usbekistan. Year: 2010
M	Flax seed shred	Purchased at BIOWELT, Am Naschmarkt 326-331, Vienna Austria. Year:2010

### 3.2 Laboratory devices

Photometer: Hitachi U9000

Laser diffraction sensor: HELOS (H1809) & RODOS

Coffee mill: Severin KM3872

### 3.3 Chemicals

Picric Acid: Purchased from Merck (CAS Number: 88-89-1)

Sadiumcarbonate  $\text{NaCO}_3$ : Purchased from Merck (CAS Number: 497-19-8)

Amygdalin from almonds: Purchased from Sigma-Aldrich (CAS Number: 29883-15-6)

$\beta$ -Glucosidase fom almonds: Purchased from Sigma-Aldrich (CAS Number: 9001-22-3)

Filter paper for test strip: Schleicher und Schull S&S Rundfilter, Whatmann 3MM

Gas chromatography vials (cm)

Phosphate Buffer solution (pH = 5), prepared as:

Solution A: 9,0786g  $\text{KH}_2\text{PO}_4$  (purchased from Merck, CAS Number: 7778-77-0) were solved in 1000 mL distilled water.

Solution B: 11,876g  $\text{Na}_2\text{HPO}_4 \cdot 2\text{H}_2\text{O}$  (purchased from Merck, CAS Number: 10028-24-7 ) were solved in 1000 mL distilled water. To 0,95 mL of solution B, solution A was added to a final volume of 100 mL.



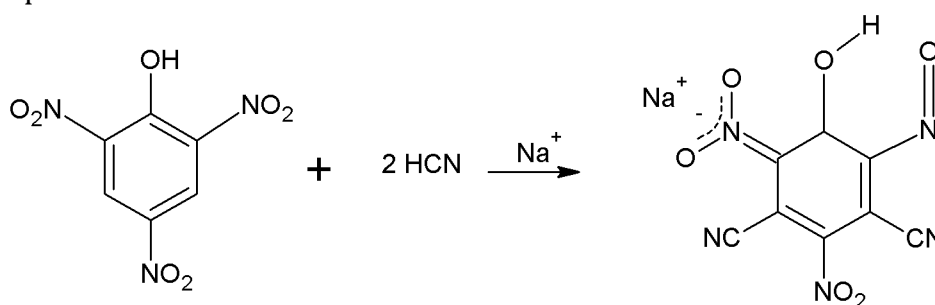
## 4. Methods

### 4.1 Picrate method for determination of total cyanide in prunus kernels

This simple and accurate method can be applied on many different kinds of samples if these are prepared correctly. It can be used for a rough estimation of cyanide by the means of a simple test strip and a colour chart. More accurate quantification can then be achieved by photometrical measurements of diluted isopurpurate from the test strip (136).

#### 4.1.1 Principle

A method of Bradbury (142) for determination of total cyanide in cassava and from Egan (143) and Haque (144) in various foods were evaluated and adapted for application on certain stone fruit species. The method is based on the reaction of hydrocyanic acid and yellow picrate to red isopurpuric acid (145) (146) on a test strip and then measured either semi-quantitative by comparison with a colour chart or diluted and measured by means of a photometer.



**Figure 4.1:** Isopurpurate reaction of picric acid (145)

#### 4.1.2 Sample Preparation and preparation of picrate paper test strips

##### 4.1.2.1 Preparation of picrate paper test strips

Sodium picrate paper is prepared by dipping filter paper into an aqueous solution of 0.5% picric acid and 5% Na<sub>2</sub>CO<sub>3</sub>, then allowing the paper to dry. The paper may be stored dry but should be moistened just before use (16) (115) (116). The filter paper chosen for preparation of test strips depends on the expected concentration. For HCN concentrations of around 40mg/kg or less Schleicher and Schüll.

##### 4.1.2.2 Preparation of homogeneous food samples like marzipan or persipan

Homogeneous food samples need no particular preparation. Due to homogeneity of the sample direct measurement is possible. The necessary sample quantity amounts to 600mg: 25-100 mg per measurement and it is recommended to do at least six measurements per sample.

Preparation of persipan: The persipan measured in this study was prepared as following: 50g where blanched for 5 minutes at 80°C, then peeled and grinded. 15g

powdering sugar was added and the mass was formed to a tube and cut into slices roasted of approximately 2.5cm, then they were roasted at 180° for 20 minutes.

#### **4.1.2.3 Preparation of apricot kernels**

For measuring the total cyanide content in apricot kernels it is necessary to grind these kernels before measuring. In order to achieve sufficient homogeneity and avoid too large heat input, an ideal grinding time of 60 seconds has to be maintained. Furthermore it is important to grind a sufficient sample quantity (45-50g) so that the mentioned heat input does not cause a too large rise in temperature. These values refer to grinding processes with a coffee mill (model: Severin KM3872). The heat entry caused by the meal process can lead to the escape of prussic acid before the gas-proof sealing of the sample and thus to falsified results. This can be observed by constant mass loss (within the range 0,1mg/s) when weighing the sample on analytical scales. Therefore solely fresh, thermally untreated and dry kernels are to be used. Aging and thermal treatment such as a freezing, blanching or roasting can lead to a change of the kernel structure and thus to a relieved escape of prussic acid. Too much moisture of the sample, probably caused by prior freezing, leads to clumping of the grains while grinding and thus to a strongly inhomogeneous sample. Ideally the sample is a fine, white powder which is weight-constant immediately after grinding.

#### **4.1.2.4 Preparation of sour cherry kernels**

Sour cherry kernels seem to be more robust than apricot kernels since the measured cyanide concentration was not influenced by the sample quantity. A sample quantity of less than 1g and a grinding time of 120s lead to acceptable results.

#### **4.1.3 Quantification of the total cyanide content in the prepared sample**

A weighed amount (25-100mg) of cyanogenic sample is placed in a small gas-proof closable glass vial (25 mm diam., 50 mm high), followed by 0.5mL of buffer solution and 5 drops of  $\beta$ -glucosidase solution (2mg/mL).

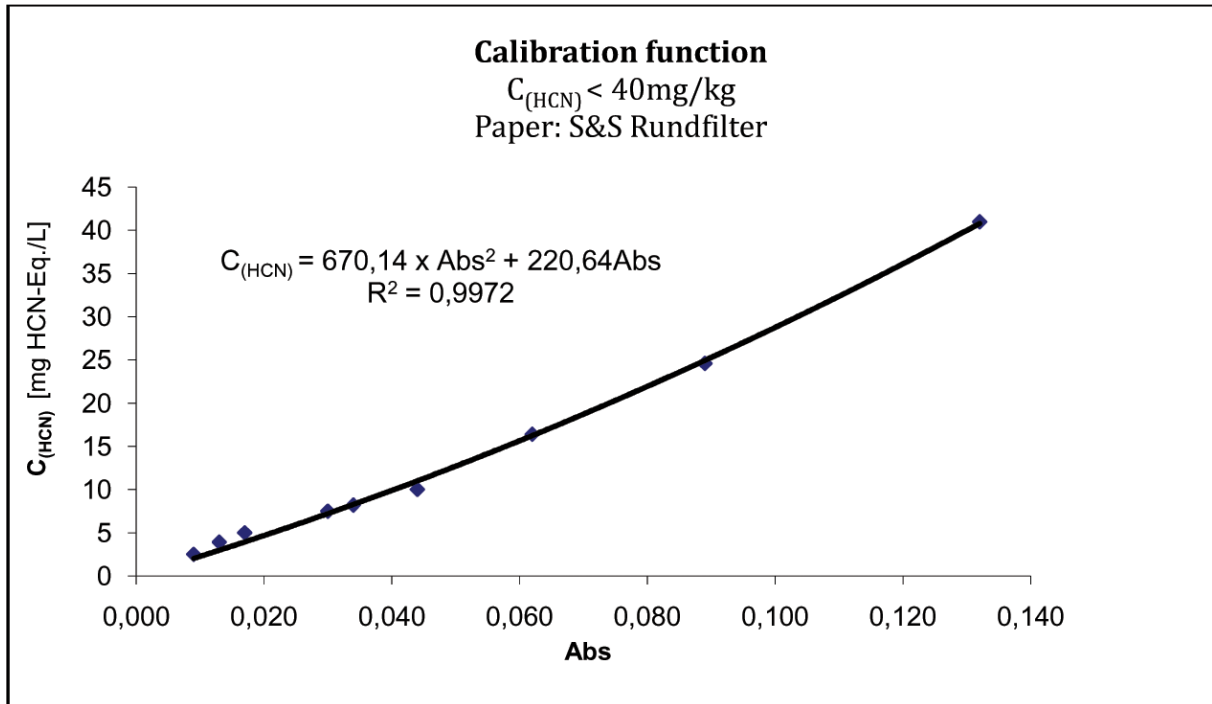
A yellow strip of filter paper (previously prepared as described above) it placed into a vial which then is immediately tightly stoppered. The vials are placed in an oven at 40°C over night for at least 20 hours and a colour change from yellow to orange to red can be observed.

The shade of colour can be compared with that of a colour chart (Figure 3.2) to obtain the approximate amount of cyanide present.

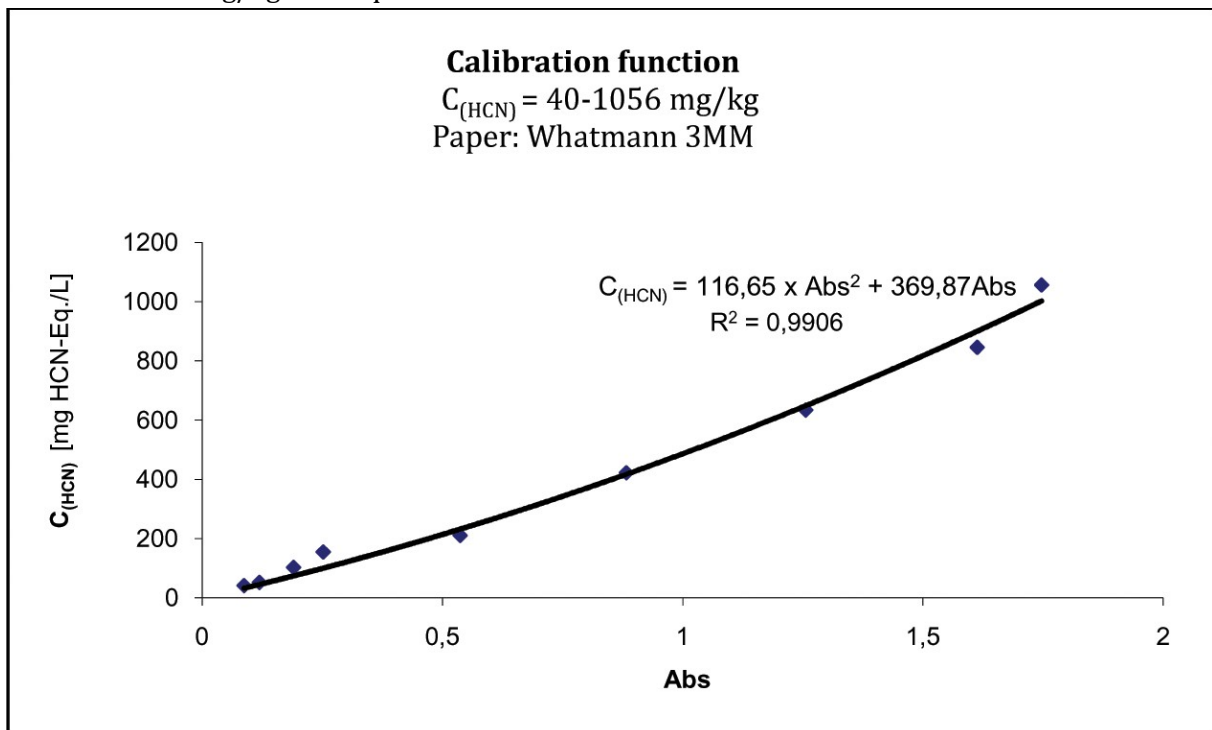


**Figure 4.2:** Colour chart for estimation of total cyanide content.

The paper is then immersed in water for 30 minutes and the absorbance of the solution is measured at 510 nm against an identically prepared blank sample developed in the absence of HCN and cyanogenic glycosides.



By means of calibration functions (Figure 3.3 and Figure 3.4) of absorbance vs. HCN content the total HCN content can be obtained more accurate. The best correlation was obtained with polynomic interpolation in second degree (136). **Figure 4.3:** Calibration function 2.5-40mg/kg HCN equivalents



**Figure 4.4:** Calibration function 40-1056mg/kg HCN equivalents

Although these calibration curves can be used for quantification of total cyanide content it is recommended to determine new calibration functions for other photometers in other laboratories.

#### 4.1.4 Method validation

The Validation was accomplished according to the *Guide to Quality in Analytical Chemistry - An Aid to Accreditation* by CITAC and EURACHEM (147).

##### 4.1.4.1 Working range

The working range of the method lies between 2.5 and 40 mg/kg HCN equivalents for S&S Rundfilter filter paper and 40-1056mg/kg HCN equivalents for the Whatmann 3MM blotting paper.

##### 4.1.4.2 Linearity

Although the correlation coefficient is closer to 1 ( $R^2 = 0,9972$  for hydrogen cyanide determination below 40mg/kg and  $R^2 = 0,9906$  above 40mg/kg) linear interpolation leads to quite applicable correlation as well.

The calibration data can be interpolated linear for both kinds of test strips:

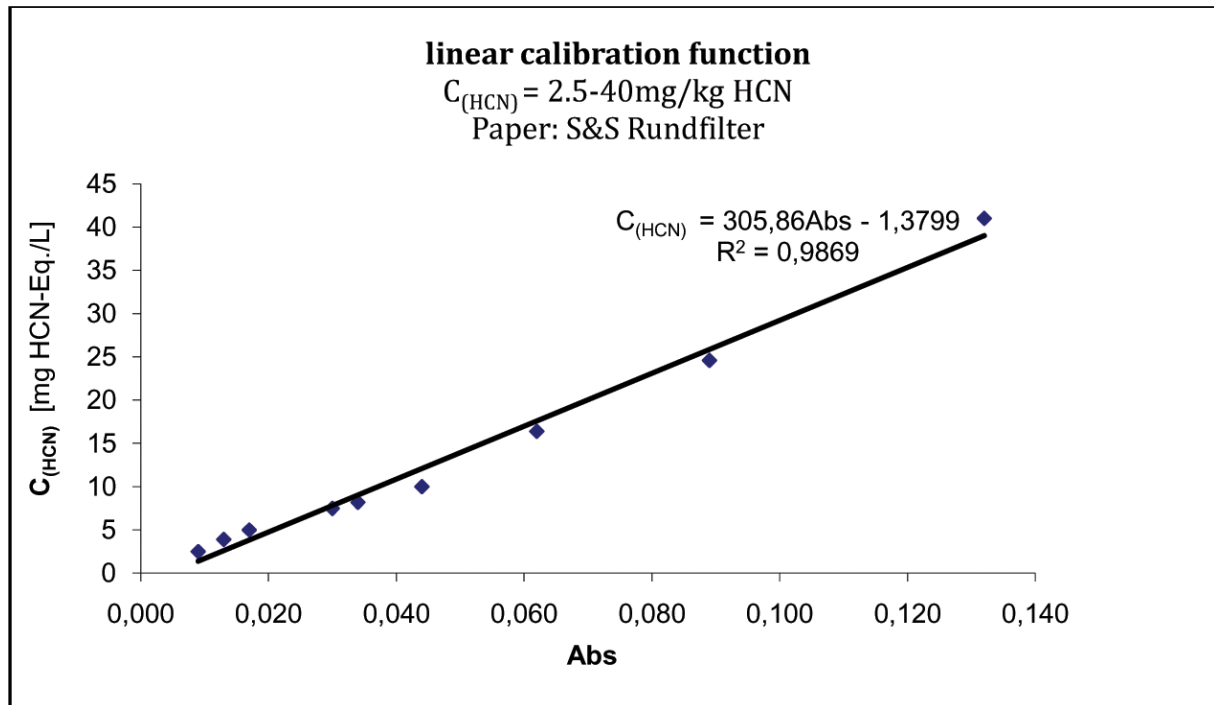
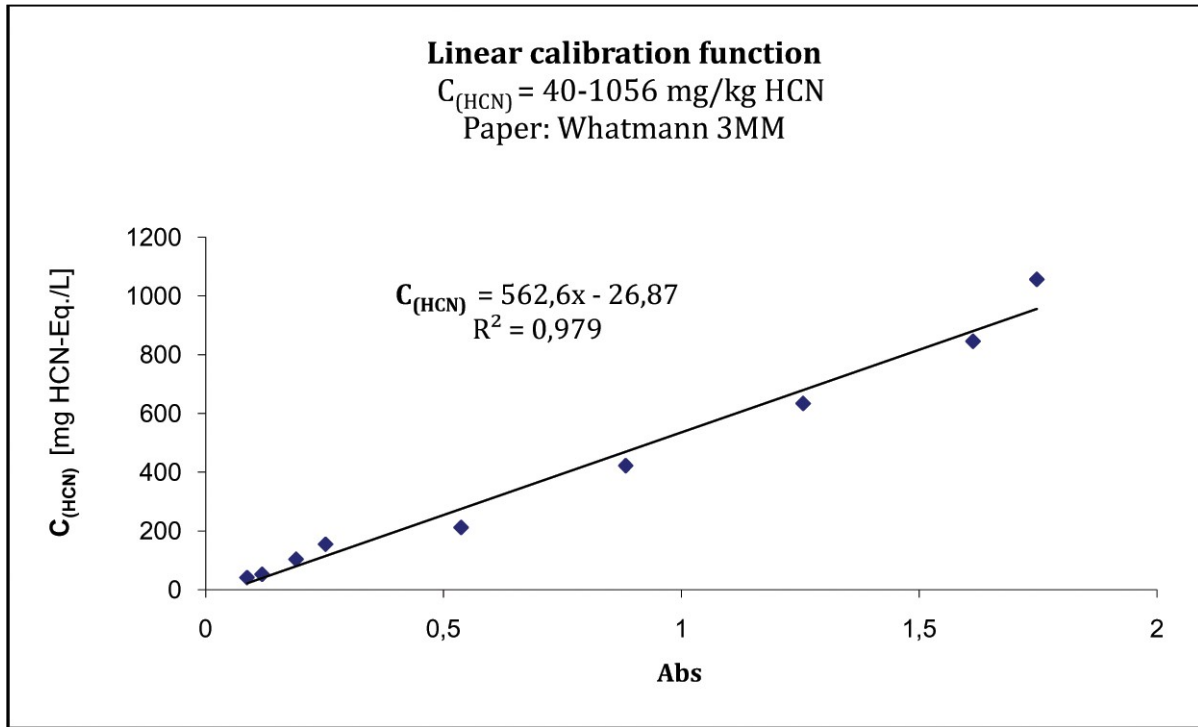


Figure 4.5: Linear calibration 2.5-40mg/kg HCN equivalents



**Figure 4.6:** Linear calibration 40-1056mg/kg HCN equivalents

**4.1.4.3 Limit of detection**

A set of blank tests was measured against water. The detection limit is equivalent to the mean blank response plus 3 standard deviations [CITAC] and results in 24mg HCN equivalents/kg.

**4.1.4.4 Limit of quantification**

The limit of quantification is defined as the lowest point in the calibration function at which an effect was observes (Lowest Observed Effect Level, LOEL) and is 2.5mg/kg HCN in the sample when measuring with the more sensitive S&S picrate paper.

#### 4.1.4.5 Precision

Regarding to the standard deviation, the precision for different concentration was determined:

C(HCN) [mg HCN-Eq./L]	Precision [%]
1056	8,09%
845	4,81%
634	6,72%
422	7,14%
211	8,62%
155	14,64%
103	4,10%
52	9,16%
41	8,97%

**Table 4.1a.:** Method precision

Whatmann 3MM paper

C(HCN) [mg HCN-Eq./L]	Precision [%]
41	2,61%
24,6	4,44%
16,4	5,69%
10	9,95%
8,2	8,12%
7,5	10,16%
5	12,86%
3,9	6,34%
2,5	13,41%

**Table 4.1b.:** Method precision

S&S Rundfilter paper

#### 4.1.4.6 Selectivity

a) Possible interference factors in the sample solution:

Chemical or physical interaction of amygdalin or HCN with other substances in the sample, such as ketones, aldehydes, fatty acids, etc. cannot be excluded. Therefore a test series with addition of a certain amount of amygdalin was done:

Sample: Sour cherry kernels, time of grinding = 120s, total sample amount: 612,6mg

Test series A: fresh sample, analysis as described

Sample	Amount [mg]	Absorbance at 510nm	HCN [mg/kg]
A1	55	1,461	1435
A2	54,8	1,528	1528
A3	42	1,257	1546
A4	38,8	1,107	1424
A5	63,1	1,524	1323
A6	26,6	0,821	1437
A7	35,3	1,089	1533
		<b>mean:</b>	<b>1461</b>
<b>standard deviation:</b>		<b>74,31</b>	<b>5,1 %</b>

**Table 4.2a.:** Test series without addition of amygdalin.

Test series B: fresh sample, addition of 100µL amygdalin solution(206mg HCN-Eq./L)

Sample	Amount [mg]	Absorbance at 510nm	HCN [mg/kg]
B1	35,3	1,176	1689
B2	72,5	1,61	1238
B3	41,4	1,139	1383
B4	51,7	1,378	1414
B5	33,5	1,064	1569
B6	20,4	0,771	1738
		mean:	1505
standard deviation:		176,24	11,7 %

**Table 4.2b.:** Test series with addition of amygdalin.

The results are in the expected range. Therefore possible loss due to interaction with the matrix is negligible.

b) Possible interference factors in the test strip:

Substances such as creatinine, lead acetate, tin chloride, amino acids and other substances, with which picric acid can react coordinatively, can influence the result. Therefore it is important to make sure the test strip is not contaminated with any of these substances.

## 4.2 Decontamination

Different methods of decontamination were tested on apricot and sour cherry samples and compared.

### 4.2.1 Decontamination using water

#### 4.2.1.1 Continuous flow decontamination

After blanching and peeling, almonds which contain the cyanogenic glycoside amygdalin (bitter almonds) are debittered by leaching with flowing water. The HCN content is reduced by 80% in 24h and the water content of the almond is raised to 38%. A prolongation of the process reduces the HCN content only minimally (104). Due to the close relationship and similarity between bitter almonds and other amygdalin containing prunus kernels, the method was tested for application on apricot and sour cherry kernels.

#### 4.2.1.2 Batch decontamination

The disadvantage of continuous flow decontamination due to the high needs of fresh water is obvious. Furthermore, the processing of the water used for decontamination for the production of natural benzaldehyde can be done more easily when the concentration of benzaldehyde is higher. Therefore decontamination by batch process was tested.

### 4.2.2 Decontamination using ethanol

Although ethanol is much more expensive than water the decontamination process with ethanol was tested due to possible application during amaretto production.



#### **4.2.3 Decontamination by heat treatment**

Grinded and whole kernels samples were put on a glass surface and stored at 80°C and 150°C for different time periods. This method did not show a significant detoxification effect (see 4.2.2).

## 5. Results

### 5.1 Preliminary tests and observations

#### 5.1.1 Apricot

**Mass ratio:**

Species: Apricot (*Prunus armeniaca*)

Cultivar: Wachauer Marille

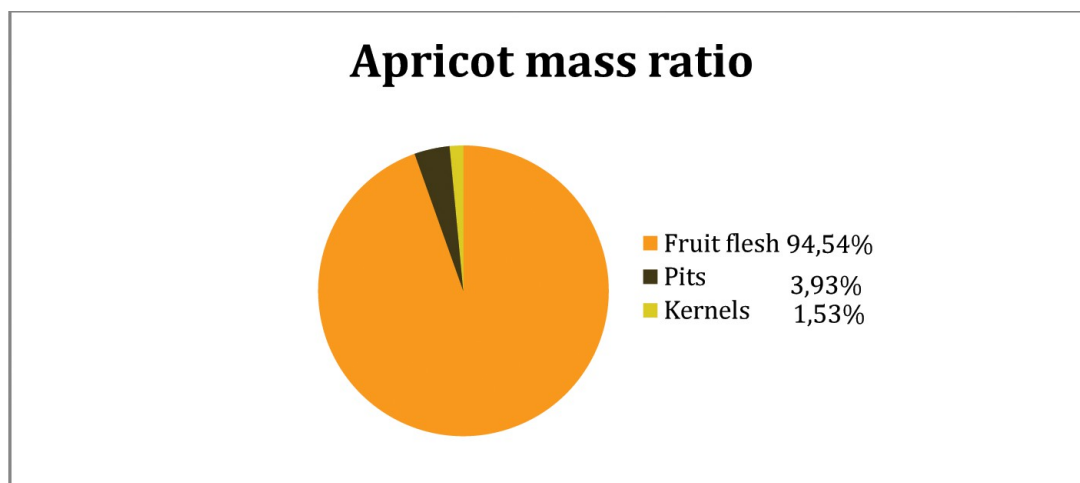
Year: 2009

Purchased at Naschmarkt, Vienna

Two samples of each 19 fruits were taken and the mass of whole fruits, moist and dried stones and kernels were weighed. The kernels were dried to constant mass for 12 days at 30°C.

Sample	Mass total [g]	Mass stones, moist [g]	Mass stones, dry [g]	Mass kernels, moist [g]	Mass kernels, dry [g]
A	989.0	54.0 (5.46%)	40,9 (4.14%)		9.88 (1.00%)
B	914.2	52.9 (5.79%)		13.97 (1.53%)	9.24 (1.01%)

**Table 5.1.:** Mass ratios of apricot kernel. Percentages refer to mass of fresh fruit.



**Figure 5.1.:** Apricot mass ratio

**Density:**

The density values of the different parts of the stone are of interest to separate these from each other by a floating and sinking process. The density of apricot kernels was estimated by measuring mass and volume of a sample:

	Mass	Volume	Density
Pit	0.5918g	0.50cm <sup>3</sup>	1.18g/cm <sup>3</sup>
Kernel	0.4036g	0.39 cm <sup>3</sup>	1.03 g/cm <sup>3</sup>

**Table 5.2.:** Measured mass and volume and calculated density of crushed apricot kernel sample. Values are inaccurate and can only be used as estimation.

Both, pits and kernel sink in distilled water. In a saturated solution of sodium chloride (density  $\rho_{\text{NaCl(sat.)}}=1.202\text{g/mL}$ , (148)) , most kernels swim on the surface of the solution whereas most parts of the pits remain sinking. This separation can as well be achieved by a sodium chloride solution of 300g/L. To optimize a separation process based on this principle an ideal sodium chloride concentration could be found in further studies.

### 5.1.2 Sour Cherry

**Mass ratio:**

The mass ratio between kernel and pits of sour cherry stones was measured. 6 samples of each 10 stones were taken.

Sample	A	B	C	D	E	F	
Total mass [g]	2,5681	2,332	2,452 5	2,564 4	2,384 7	2,4166 5	
Kernel mass [g]	0,7591	0,562 3	0,626 4	0,697 7	0,569 7	0,6379	
mass ratio kernels to stone [%]	29,56 %	24,11 %	25,54 %	27,21 %	23,89 %	26,40 %	<b>26,12 %</b>

**Table 5.3.:** Masses and mass ratio of sour cherry stone and kernel. Every sample consisted of 10 stones.

**Density**

Due to the higher density of sour cherry kernels compared to apricot kernels, sour cherry kernels cannot be separated with a saturated sodium chloride solution sufficiently. The crushed kernels showed better separation by floating and sinking process in a more dense saturated magnesium sulphate solution.

## 5.2 Total HCN content in stone fruit kernels and foods containing these

Some stone fruit kernels and food samples were tested on their total hydrogen cyanide content.

Sample	Type	Details	total hydrogen cyanide content [mg/kg]
A	Sour cherry kernels	Harvested from a sour cherry tree in a private garden in Vienna, Austria Year: 2009	1521 ± 121 mg/kg
B	Apricot kernels	<i>Wachauer Marille</i> from Obstgarten Reisinger, Mitterndorf am Jauerling 1, A-3620 Spitz an der Donau, Austria. Year: 2009	801 ± 78 mg/kg
C	Apricot kernels	<i>Naturgarten Bio-Aprikosenkerne</i> , purchased at BIOWELT, Am Naschmarkt 326-33, Vienna, Austria Year: 2009	1971 ± 153 mg/kg
D	Apricot kernels	Purchased open (without label in a plastic bag) at Am Naschmarkt 496, Vienna, Austria Origin: Usbekistan. Year: 2009	2246 ± 79 mg/kg
E	Apricot kernels, roasted	<i>Wachauer Marille</i> , Wieser Geröstete Marillenkerne, purchased from MARKUS WIESER GMBH - ÖSTERREICH 3610 Weissenkirchen in der Wachau, Wösendorf 13, Austria Year: 2009	Sample 1: 60 ± 6 mg/kg Sample 2: 28 ± 3 mg/kg
F	Bitter almonds	Naturgarten Bittermandeln, purchased at BIOWELT, Am Naschmarkt 326-331, Vienna Austria Origin: Usbekistan Year: 2009	2402 ± 139 mg/kg
G	Sweet almonds	Purchased without label at Am Naschmarkt 613; Origin: Italy Year: 2009	below limit of detection
H	Marzipan filling	Apricot marzipan filling from "Marillen-Duett" chocolate, contains apricot kernels, purchased at BIOWELT, Am Naschmarkt 326-331, Vienna Austria Year: 2009	below limit of detection
I	Chocolate	"Marille mit Krokant", contains 4% apricot kernels, purchased at BIOWELT, Am Naschmarkt 326-331, Vienna, Austria. Year: 2009 Year: 2009	below limit of detection
K	Cherry kernles	From <i>Kirschkernkissen (cherry stone cushion)</i> , purchased at Bipa, Erdbergerstraße 52-60, Vienna, Austria. Year: 2010	105 ± 8 mg/kg

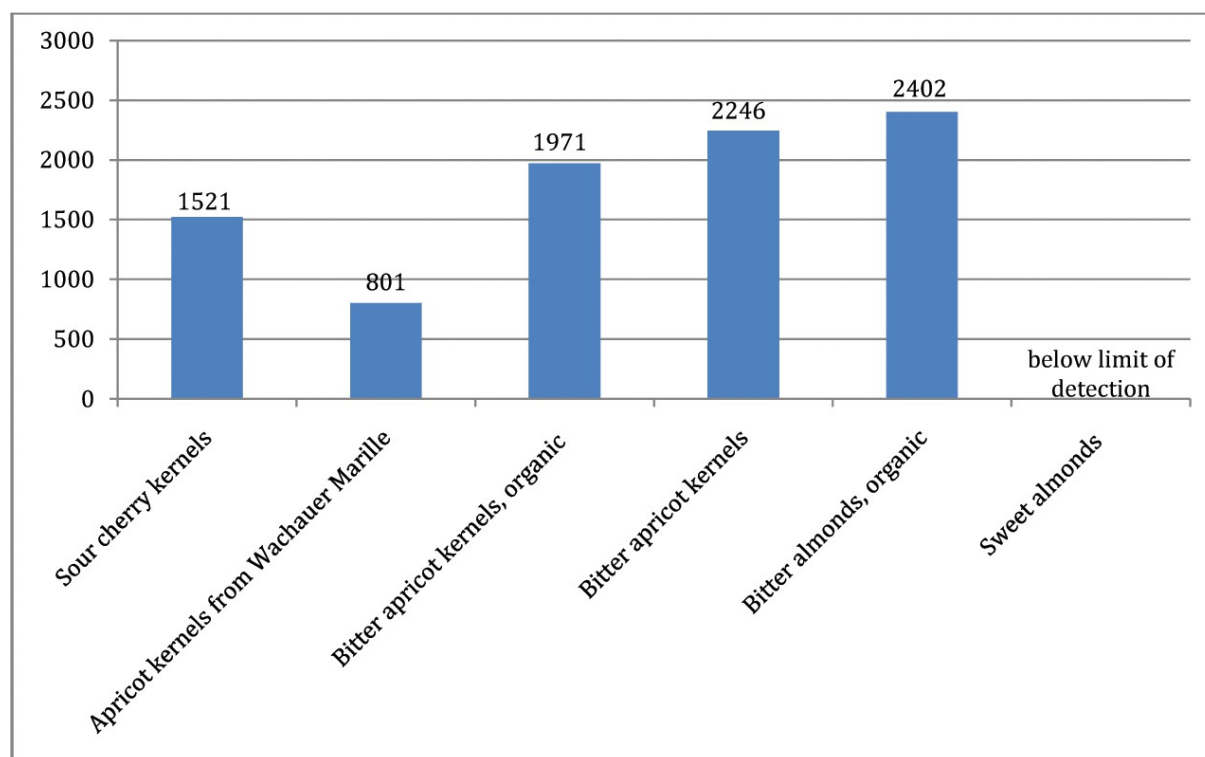
QUANTIFICATION OF TOTAL CYANIDE CONTENT IN KERNELS OF STONE FRUITS

L	Flax seed	Purchased open (without label in a plastic bag) at Am Naschmarkt 496, Vienna, Austria Origin: Usbekistan. Year: 2010	120 ± 35 mg/kg
M	Flax seed shred	Purchased at BIOWELT, Am Naschmarkt 326-331, Vienna Austria. Year:2010	113 ± 37 mg/kg

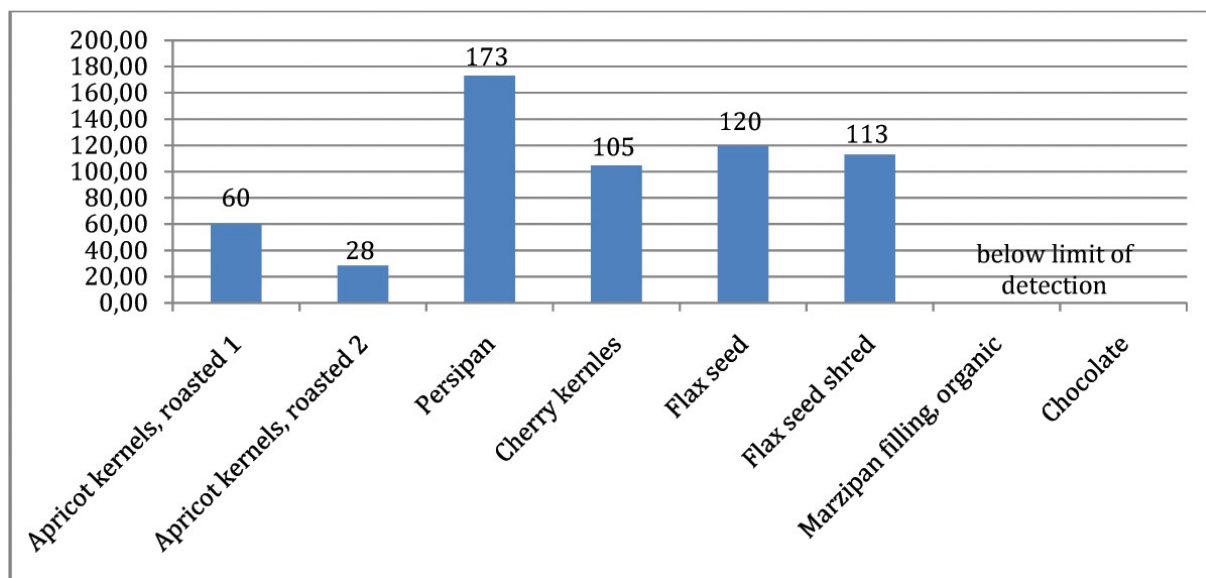
**Table 5.3.:** Measured kernel and food samples

The concentration of total hydrogen cyanide varies between different species and cultivars. In all apricot and sour cherry kernels high concentrations of hydrogen cyanide was measured. Therefore untreated apricot and sour cherry kernels are no appropriate food for human nutrition or animal feed.

A relatively low concentration in the cultivar *Wachauer Marille* was measured which indicates that, after a step of debittering, the kernels of this cultivar might be an interesting option as alternative food source.



**Figure 5.2.:** Hydrogen cyanide content of various stone fruit kernels [mg/kg]



**Figure 5.3.:** Hydrogen cyanide content of various foods containing stone fruit kernels [mg/kg]

Self made persipan and some commercial available foods such as roasted apricot kernels, flax seed, flax seed shred contain considerable concentrations of hydrogen cyanide. Also cherry kernels from cherry stone cushion contain hydrogen cyanide. These cushions are intended to be heated up in microwave ovens so they can act as heat accumulator. It would be of interest to study the liberation of hydrocyanic acid of these cushions when used in this way.

Other foods like chocolate and marzipan filling using apricot kernels contain no hydrogen cyanide.

### 5.3 Effects of debittering

#### 5.3.1 Effects of debittering by leaching in water

##### 5.3.1.1 Continuous flow debittering

###### Continuous flow debittering applied on apricot:

Approximately 50g apricot kernels were blanched (80°C, 5 min), peeled and put under flowing water (43mL/s; 5°C). During the process the mass increased to almost 160%. The kernels were analysed after 8h and 24h. After 8h the HCN content decreased from 801.32± 77.53 mg/kg to 23.78 ± 0.94 mg/kg which accords to a decrease of 97.0 %. After treatment for 24h the HCN content decreased to 12.19± 9.46 mg/kg which accords to a decrease of 98.4 %.

###### Continuous flow debittering applied on sour cherry:

Approximately 2g sour cherry kernels were blanched (80°C, 5 min), peeled and put under flowing water (43mL/s; 5°C). Within the process the mass increased to 121%. The kernels were analysed after 8h and 24h.

After treatment for 8h the HCN content decreased from 1520.79 ± 120.94 mg/kg to 339.25 ± 15.59 mg/kg which accords to a decrease of 77.7 %. After treatment for 24h the HCN content decreased to 263.54± 19.20 mg/kg which accords to a decrease of 82.7 %.

### 5.3.1.2 Batch debittering

#### Batch debittering apricot

45g apricot kernels were blanched (80°C/5min) and put in a beaker with 200mL tap water. The beaker was closed with a watch glass. After 4h the water was decanted (debittering water 1: DB1) and replaced by fresh 200mL (DB2). After further 4 hours the water was removed and the kernels were analysed on HCN content. After 8h the HCN content decreased from 801.32 +/- 77.53 mg/kg to 29.46 +/- 1.63 mg/kg which accords to a decrease of 96.3 %.

The analysis of the water used for debittering yielded these results:

**DB1: 24,3 +/- 1,1 mg/kg**

**DB2: 14,7 +/- 0,4 mg/kg**

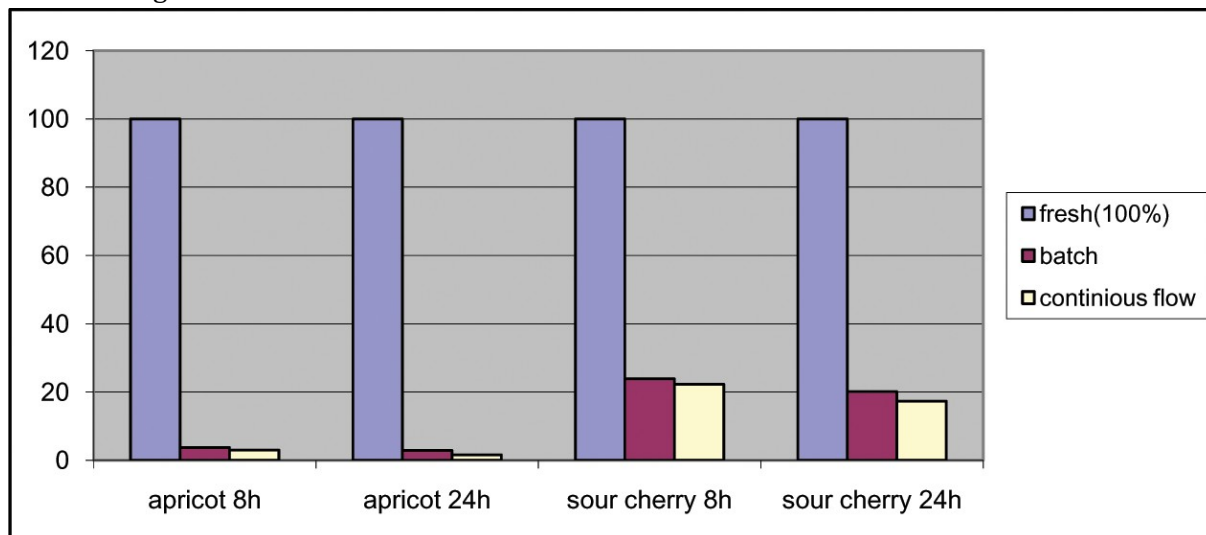
45g of apricot kernels which were debittered in batch for 24h in 200mL water, the HCN content decreased to 23.5 +/- 1,7mg/kg which accords to 97.1%.

#### Batch debittering sour cherry

Approximately 2g sour cherry kernels were blanched (80°C/5min) and put in a beaker with 20mL tap water. The beaker was closed with a watch glass. After 4h the water was decanted and replaced by fresh 20mL. After further 4 hours the water was removed and the kernels were analysed on HCN content. After 8h the HCN content decreased from 1520.79 +/- 120.94 mg/kg to 363.47 +/- 20.01 mg/kg which accords to a decrease of 76.1 %.

2g of apricot kernels which were debittered in batch for 24h in 20mL water, the HCN content decreased to 305.31 +/- 20.25mg/kg which accords to 79.9%.

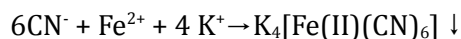
Compared to the debittering by continuous flow, this method shows to be almost as efficient while having much lower water need.



**Figure 5.4:** Effects of different process variations of debittering stone fruit kernels with water.

#### Precipitation of CN<sup>-</sup> in the water used for debittering

In order to process the cyanide containing water used for debittering of stone fruit kernels, it is necessary to remove the toxic HCN. One simple way to do this is by precipitation as potassium ferrocyanide:



To 1mL of the DB1 solution 10 drops of 0,05M KOH and 0,05M Fe(II)SO<sub>4</sub> were added. A greenish-yellow precipitation was observed. The analysis of this solution resulted in 8,86 +/- 0,57 mg/L HCN. This accords to a decrease of 63.5%. An optimization of this step could be achieved by further studies.

### 5.3.2 Effects of debittering by leaching in ethanol

Debitting of sour cherry kernels in ethanol for four days (batch) supplied significant results. Detoxification was not as efficient as with water, although this data could be considered during amaretto production.

### 5.3.3 Effects of debittering by heat treatment

The attempt of roasting the kernels at temperatures of 80° for seven days and 150°C for 24 hours did not lead to any satisfying results. Debitting of stone fruit kernels by heat treatment is not a functional method.

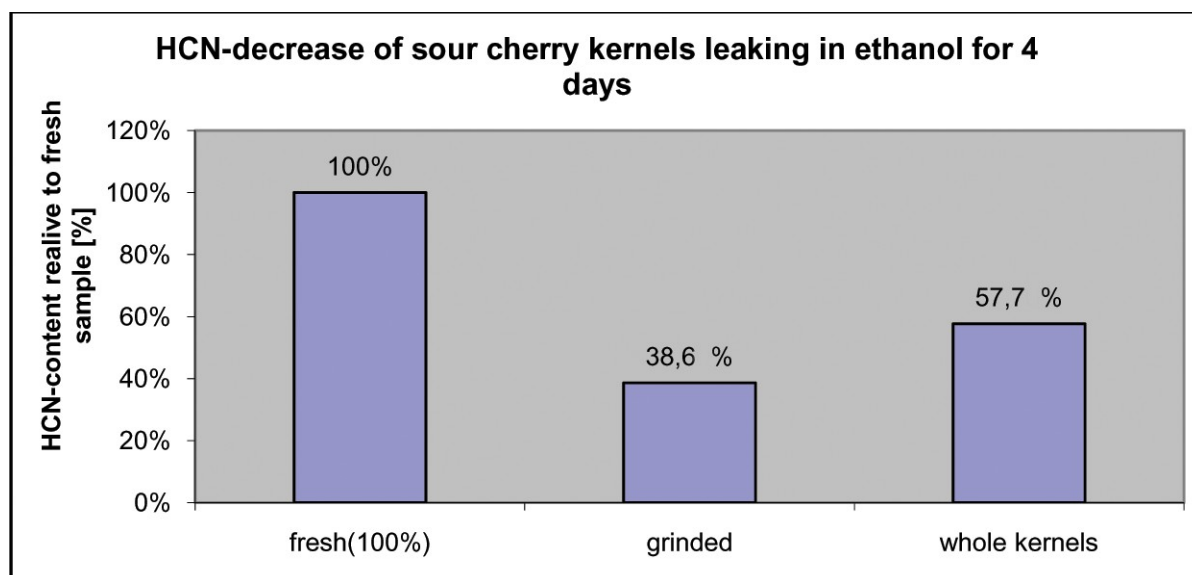


Figure 5.5: HCN-decrease of sour cherry kernels leaching in ethanol

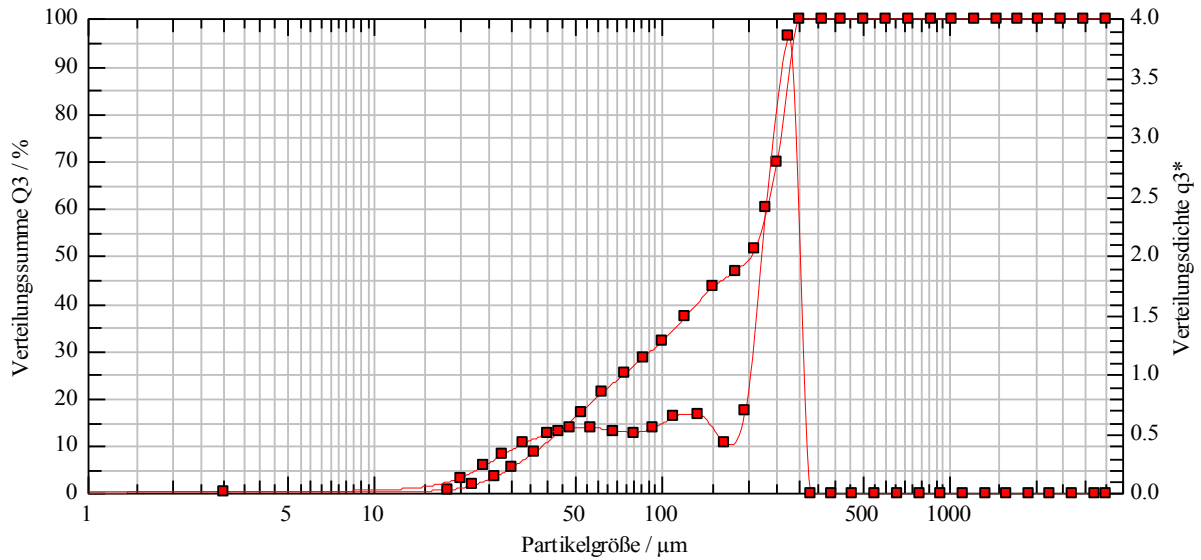
## 5.4 Particle size distribution

For optimizing sample preparation particle size distribution was measured of apricot kernel powder after grinding for 30 and 60 seconds, respectively. The particle size distributions were measured by laser diffraction. Device: HELOS (H1809) & RODOS, Settings: R7: 0.5/18.0...3500µm

The results show that to achieve a useful sample a grinding time of 60 seconds is necessary. Grinding the sample for only 30 seconds leads to wide range particle size distribution, which leads to irreproducible results of HCN content.



**Apricot, grinding time 30s**



**Figure 5.6.:** Particle size distribution of apricot kernel powder, grinded for 30 seconds.

$x_{10} = 38,51 \mu\text{m}$ $x_{50} = 170,10 \mu\text{m}$ $x_{90} = 240,43 \mu\text{m}$  SMD = $133,48 \mu\text{m}$ VMD = $165,84 \mu\text{m}$	$x_{50} = 201,15 \mu\text{m}$	$x_{90} = 283,56 \mu\text{m}$	First complete momentum (areic): SMD = $91,72 \mu\text{m}$	First complete momentum (massic): VMD = $171,18 \mu\text{m}$
$x_{16} = 50,08 \mu\text{m}$	$x_{84} = 273,70 \mu\text{m}$	$x_{99} = 298,36 \mu\text{m}$	Particle volume specific surface area: $S_V = 0,07 \text{ m}^2/\text{cm}^3$	Particle mass specific surface area: $S_m = 250,63 \text{ cm}^2/\text{g}$
			Mode of mass specific particle size distribution: $M_{od} = 275,00 \mu\text{m}$	Median of mass specific particle size distribution: $M_{ed} = 201,15 \mu\text{m}$

**Table 5.4.:** Particle size distribution data of apricot kernel powder, grinded for 30 seconds.

When measuring this sample problems occurred. The high oil content of the sample led to agglomeration and blockage of the disperser.

Apricot grinding time 60s

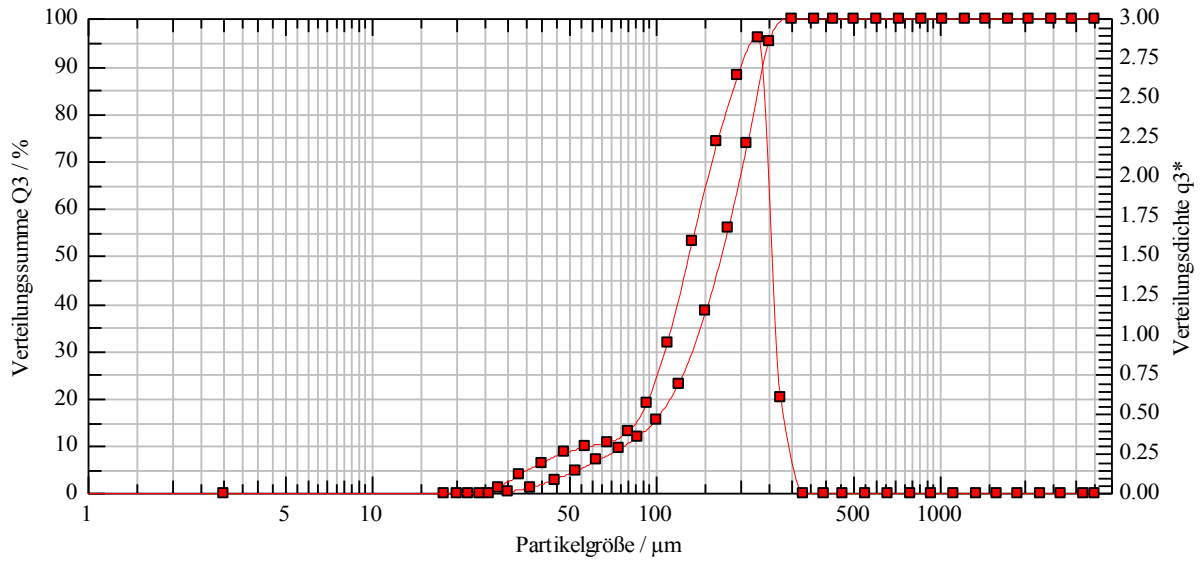


Figure 5.7.: Particle size distribution of apricot kernel powder, grinded for 60 seconds.

QUANTIFICATION OF TOTAL CYANIDE CONTENT IN KERNELS OF STONE FRUITS

---

$x_{10} = 77,93 \mu\text{m}$ $x_{50} = 170,10 \mu\text{m}$ $x_{90} = 240,43 \mu\text{m}$  SMD $= 133,48 \mu\text{m}$ VMD $= 165,84 \mu\text{m}$	$x_{50} = \mathbf{170,10 \mu\text{m}}$	$x_{90} = \mathbf{240,43 \mu\text{m}}$	First complete momentum (areic): SMD= <b>133,48 <math>\mu\text{m}</math></b>	First complete momentum (massic): VMD = <b>165,84 <math>\mu\text{m}</math></b>
$x_{16} = 101,68 \mu\text{m}$	$x_{84} = 229,41 \mu\text{m}$	$x_{99} = 289,56 \mu\text{m}$	Particle volume specific surface area: $S_v = 0,04 \text{ m}^2/\text{cm}^3$	Particle mass specific surface area: $S_m = 374,60 \text{ cm}^2/\text{g}$
			Mode of mass specific particle size distribution: $M_{od} = 195,00 \mu\text{m}$	Median of mass specific particle size distribution: $M_{ed} = 170,10 \mu\text{m}$

**Table 5.5.:** Particle size distribution data of apricot kernel powder, grinded for 60 seconds.

## **6. Discussion**

### **6.1 Method**

The picrate paper method for determination of total cyanide is a simple, accurate and inexpensive method, therefore suitable for analysis of stone fruit kernels and products made from these, especially of intermediate products during the process of debittering. Approximate estimations of cyanide content can be done in gas-proof vials by the means of simple test strips, a colour chart,  $\beta$ -glucosidase and buffer solutions without expensive laboratory equipment. More accurate cyanide quantification can be then be achieved by deluting the colour from the test strip in water and subsequent photometrical measurements. Even higher accuracy can be performed by other methods such as HPLC. No side reactions have been observed which would influence the results. In case of high cyanide concentrations, a saturation of the testing strip is possible. This can result in a measured lower concentration. To avoid this, the maximum measurable concentration of the testing strip needs to be taken into consideration.

### **6.2 Sustainability of stone fruit kernels**

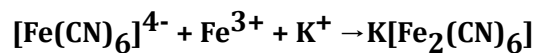
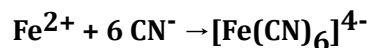
The advantages of utilizing amygdalin containing stone fruit kernels are obvious. Huge amounts of stone fruit kernels, which are littered or composted every year, can be used as a source for high quality food: persipan, stone fruit edible oil and natural bitter almond essential oil. Persipan is a cheaper alternative product to marzipan. Flavor, quality and composition of both products are similar to each other, whereas persipan is made of stone fruit kernels instead of almonds. A step of debittering is necessary. This is possible with water and/or precipitation of cyanide with Fe(II) and can be optimized for less water usage and time consumption.

Stone fruit oil contains many unsaturated fatty acids and high concentrations of tocopheroles (104). Additionally the presence of natural benzaldehyde gives the oils a delicate, marzipan-like fragrance and taste. Due to the insolubility of hydrogen cyanide in apolar solvents like edible oil there is no step of debittering necessary and no danger of intoxication by stone fruit edible oils. After detoxification the press cake remaining after production of stone fruit kernel edible oil can be used as animal feed.

Natural benzaldehyde, or bitter almond oil is a natural essential oil which can be used as natural flavor for many products as an alternative to synthetic benzaldehyde which is used for marzipan aroma in many products. The hard pits then can be used for heat production, which can be used as energy to fuel the machines used for separating and processing the kernels.

### 6.3 Toxicity of stone fruit kernel products

The main disadvantage of utilization of stone fruit kernels is their toxicity due to the high content of amygdalin. Apricot kernels contain substantially less amygdalin than kernels from sour cherry. Yet both products must be debittered before consumption. The most efficient and less expensive process for debittering is extraction with cold water done twice. The cyanide ions within the extraction solution then can be made harmless by complexation with Fe(II)-ions and then precipitated with Fe(III)-ions and K<sup>+</sup> as potassium ferrocyanide:



The analyzed content of cyanide in commercial available stone fruit preserve exceeded clearly the legal limit of 50mg/kg. The consumption of such products is strictly not recommended for health reasons (149).

Currently there is no obligation to label the content of cyanogen glycosides like amygdalin within the EU. Bitter almonds are usually only commercially available in small units of 50g. The packaging carries a warning on the label, that states „Only for cooking and baking purposes. Keep out of reach of children. Not fit for raw consumption.“ Currently bitter apricot kernels are sold for raw consumption, which carries the same risks as raw bitter almonds. They are not sold in small units, but in units of 200g instead. Research by the Lebensmittelinstitut Braunschweig in 2006 proved a comparable amount of cyanide in the apricot kernels as in bitter almonds. In six samples of different vendors, the amount of cyanide was measured between 1949 mg/kg and 2934 mg/kg. Only one of the samples carried a warning label, and this label only stated to keep it out of reach of children. The lowest lethal dose of cyanide for an adult is between 0.5 to 3.5 mg/kg Bodyweight (EFSA 2004). According to a risk assessment by the British Committee on Toxicity, the daily intake of cyanide should not exceed 0.02 mg/kg bodyweight, while the expert committee „Aromastoffe“ published a Temporary Maximum Daily Intake (TDMI) of 0.023 mg/kg bodyweight in 2005. Thus, within the investigated samples, a lethal dose for an adult could not be reached with the amount of ten apricot kernels, but the maximum acceptable amount of 0.02 mg/kg body weight was already exceeded with one kernel.

Bitter apricot kernels are promoted for alternative cancer treatment and sold via the internet and specialized stores for organic food, which is not supported by medical research. A common indication on the label of apricot kernels sold this way is that „apricot kernels are rich in vitamin B17“. The usage of the term vitamin implicates a health benefit and no risk at higher consumption levels. Vitamin B17 is the given name for the cyanogenic glycoside amygdalin. Amygdalin does not have vitamin properties. The samples labelled „Aprikosenkerne bitter“ were classified as hazardous to health in

accordance with Artikel 14 Abs. 2a der VO(EG) Nr. 178/2002. Even apricot kernels marketed as „Sweet Apricot Kernels“ could contain considerable amounts of cyanide; two samples from turkey contained between 200 and 400 mg/kg. The labelling advertised them as „a real alternative to almonds. Apricot kernels also taste good as a snack or as a addition for muesli.“ Sweet and bitter apricot kernels are only marginally differing in the way the look. A selection of the bitter kernels is not possible, the samples received an objection. Fourteen further samples of „Sweet Apricot Kernels“ of turkish origin contained under 70 mg/kg, which allowed to classify the consumption as unproblematic (150).

The hydrocyanic acid is created during digestion and can result in a severe, acute poisoning with the symptoms of cramps, emesis and dyspnea. A high dose can result in death by respiratory paralysis. Those symptoms can already arise by the consumption of only a few kernels. Because of this, the recommended intake of bitter apricot kernels for adults should not exceed one or two per day, and it might even be advisable to abstain completely from eating the kernels and using products containig amygdalin (151).

In my opinion it would be necessary to distribute more information about these foods and substances to the people and indicate cyanogenic food products as such. Warnings for maximal daily consumption should be mandatory on the label of the products. Furthermore, it would be possible to protect people which insist, for whatever reason, on high doses of amygdalin by administering substances with cyanide antidotes effects like sodium thiosulfate  $\text{Na}_2\text{S}_2\text{O}_3$ . The capacity of detoxification can be increased remarkable by intake of mobile sulphur, e.g. as sodium thiosulfate  $\text{Na}_2\text{S}_2\text{O}_3$ .

#### **6.4 Labelling obligation of food products with hydrocyanogenic potential**

The Regulation (EU) No 1169/2011 of the European Parliament and of the Council of October 25, 2011 aims the attainment of a high level of consumer protection and says the free movement of safe and wholesome food is an essential aspect of the internal market and contributes significantly to the health and well-being of citizens, and to their social and economic interests and that in order to achieve a high level of health protection for consumers and to guarantee their right to information, it should be ensured that consumers are appropriately informed as regards the food they consume. Consumers' choices can be influenced by, inter alia, health, economic, environmental, social and ethical considerations. It is a general principle of food law to provide a basis for consumers to make informed choices in relation to food they consume and to prevent any practices that may mislead the consumer. The Regulation (EU) No 1169/2011 is aimed to serve the interests of the internal market by simplifying the law, ensuring legal certainty and reducing administrative burden, and benefit citizens by requiring clear, comprehensible and legible labelling of foods. In order to enable food information law to adapt to consumers' changing needs for information, any considerations about the need for mandatory food information should also take account of the widely demonstrated interest of the majority of consumers in the disclosure of certain information (152). The

Regulation (EU) No 1169/2011 Annex II contains a list of substances or products causing allergies or intolerances but does not mention toxic or potentially toxic substances or products such as amygdalin and other cyanogenic glycosides.

In my opinion it would be necessary to distribute more information about these foods and substances to the people and indicate cyanogenic food products as such. Warnings for maximal daily consumption should be mandatory on the label of the products. Furthermore, it would be possible to protect people which insist, for whatever reason, on high doses of amygdalin by administering substances with cyanide antidotes effects like sodium thiosulfate  $\text{Na}_2\text{S}_2\text{O}_3$ . The capacity of detoxification can be increased remarkable by intake of mobile sulphur, e.g. as sodium thiosulfate  $\text{Na}_2\text{S}_2\text{O}_3$ .

## 6.5 Conclusion and outlook

In general, the utilization of stone fruit kernels within the EU can be considered as reasonable, as long as there is an awareness of the potential hazards and as long as suitable precautions are realized. The extraction with water in a batch process is an economic process for reducing the amount of amygdalin.

Furthermore, it has been shown that the amount of amygdalin in stone fruit kernels has strong variations. Those variations depend strongly on the species and the variety. The dependence of the amount of amygdalin on producing region, crop year and further factors like fertilization can be researched in continued studies. The results of these studies could improve the cultivation of stone fruits with kernels with a low amount of amygdalin.

Measuring the concentration of hydrocyanic acid with a picrate test strip is a method that can be used in further studies at a reasonable price.

## 7. Abbreviations

Abs	absorption
ADGH	amygdalin diglucosidase
AH	amygdalin hydrolase
bw.	bodyweight
CG	cyanogenic glycosides
Cyt P450	cytochrome P450
diam.	diameter
EC	enzyme commission number
etc.	et cetera
GC	gas chromatography
HPLC	high pressure liquid chromatography
LOEL	lowest observed effect level
MECK	micellar electrokinetic chromatography
MS	mass spectroscopy
SDE	simultaneous distillation-extraction
spp.	subspecies
UDP	Uridine diphosphate
UDPG	uridindiphosphoglucose
vs.	versus



## References

1. *The study of work process and determination of some working parameters in an apricot pit processing plant in Turkey.* **Gezer I. and S. Dikilitas.** s.l. : Journal of Food Engineering, 2002, Vol. 53 (2002), pp. 111–114.
2. *NAWARO Cascading Pilot.* **Mackwitz, H.** s.l. : Bundesministerium für Verkehr, Innovation und Technologie, 2006.
3. *VERORDNUNG (EG) Nr. 1334/2008 DES EUROPÄISCHEN PARLAMENTS UND DES RATES.* 2008.
4. *Bitterness in Almonds.* **Sanchez-Perez, R., Jørgensen, K., Olsen, C.E. , Dicenta, F. and Møller, B.L.** 2008, Plant Physiol. , Vol. 146.
5. *Toxic Substances in Crop Plants.* **Davis, R.H.** Cambridge, UK : Royal Society of Chemistry, 1991, pp. 202-225. ISBN 0-85186-863-0.
6. *Cyanogenic glycosides.* **Lechtenberg M., Nahrstedt A.** [ed.] R. Ikan. Chichester : John Wiley and Sons, UK, 1999, In R Ikan, ed, Naturally Occurring Glycosides., pp. 147–191. 0-471-98602-X.
7. *Bitterness of kernels of almond x peach hybrids and their parents.* **McCarty C.D, Leslie J.W., Frost H.B.** s.l. : Proc Am Soc Hortic Sci, 1952, Vol. 59, pp. 254–258.
8. *Cyanogenic compounds.* **Conn, E.E.** 1980, Annu Rev Plant Physiol, Vol. 31, pp. 433–451.
9. *Pattern of the cyanide-potential in developing fruits.* **Frehner M., Scalet M., Conn E.E.** 1990, Plant Physiol, Vol. 94, pp. 28–34.
10. *Biosynthesis of cyanogenic glycosides, cyanolipids and related compounds.* **Møller B.L., Seigler D.S.** [ed.] BK Singh. New York : Marcel Dekker, 1991.
11. *Tissue and subcellular localization of enzymes catabolizing (R)-amygdalin in mature Prunus serotina seeds.* **Swain E., Li C.P., Poulton J.E.** 1992, Physiol Plant , Vol. 100, pp. 291–300.
12. *Tissue level compartmentation of (R)-amygdalin and amygdalin hydrolase prevents large-scale cyanogenesis in undamaged Prunus seeds.* **Poulton J.E., Li C.P.** 1994, Plant Physiol, Vol. 104, pp. 29–35.
13. *Analisis de glucosidos cianogenicos en variedades de almendro: implicaciones en la mejora genetica.* **Arrazola, G.** s.l. : Universidad de Alicante, Alicante, Spain, 2002, PhD thesis.
14. *Relationship between cyanogenic compounds in kernels, leaves, and roots of sweet and bitter kernelled almonds.* **Dicenta F., Martinez-Gomez P., Grane N., Marti n ML, Leon A., Canovas J.A., Berenguer V.** 2002, J Agric Food Chem , Vol. 50, pp. 2149–2152.
15. *Cyanogene Verbindungen, Chemotaxonomie der Pflanzen, Vol.7.* **Hegnauer, R.** Basel : Birkhäuser Verlag, 1986, Vol. 7.
16. *Secondary Plant Metabolism.* **Seigler, David S.** pp. 273-299.

17. *Characterization of cyanogenic glycosides, cyanolipids, nitroglycosides, organic nitro compounds and nitrile glucosides from plants.* **A.M., Seigler D.S. and Brinker.** London : Academic Press, (1993), pp. 51-93.
18. *Cyanogenic glycosides; a case study for evolution and application of cytochromes P450.* **Bak S., Paquette S.M., Morant M., Rasmussen A.V., Saito S., Bjarnholt N., Zagrobelny M., Jørgensen K., Hamann T., Osmani S., et al.** 2006, *Phytochem Rev*, Vol. 5, pp. 309–329.
19. *Cyanogenic glycosides.* **Conn, E.E.** 1969, *J Agric Food Chem*, Vol. 17, pp. 519–526.
20. *Cyanogenic compounds as protecting agents for organisms.* **Nahrstedt, A.** 1985, *Plant Syst Evol*, Vol. 150, pp. 35–47.
21. *Cyanogenesis in animal-plant interactions.* **Jones, D.A.** s.l. : Ciba Foundation Symposium. John Wiley & Sons, Chichester, UK, (1988), pp. 151–170.
22. *Plant cytochromes P450: tools for pharmacology, plant protection and phytoremediation.* **Morant M., Bak S., Møller B.L., Werck-Reichhart D.** 2003, *Curr Opin Biotechnol*, Vol. 14, pp. 151–162.
23. *Reconstitution of cyanogenesis in barley (*Hordeum vulgare* L.) and its implications for resistance against the barley powdery mildew fungus.* **Nielsen K.A., Hrmova M., Nielsen J.N., Forslund K., Ebert S., Olsen C.E., Fincher G.B., Møller B.L.** 2006, *Planta*, Vol. 223, pp. 1010–1023.
24. *The cyanogenic glucoside composition of *Zygaena filipendulae* (Lepidoptera: Zygaenidae) as effected by feeding on wild-type and transgenic *Lotus* populations with variable cyanogenic glucoside profiles.* **Zagrobelny M., Bak S., Ekstrøm C.T., Olsen C.E., Møller B.L.** 2007a, *Insect Biochem Mol Biol*, Vol. 37, pp. 10–18.
25. *Intimate roles for cyanogenic glucosides in the life cycle of *Zygaena filipendulae* (Lepidoptera, Zygaenidae).* **Zagrobelny M., Bak S., Olsen C.E., Møller B.L.** 2007b, *Insect Biochem Mol Biol*, Vol. 37, pp. 1189–1197.
26. *Cyanogenic glucosides and plant-insect interactions.* **Zagrobelny M., Bak S., Rasmussen A.V., Jørgensen B., Naumann C.M., Møller B.L.** 2004, *Phytochemistry*, Vol. 65, pp. 293–306.
27. *Metabolism of cyanogenic glucosides in *Hevea brasiliensis*.* **Lieberei R., Selmar D., Biel B.** 1985, *Plant Syst Evol*, Vol. 150, pp. 49–63.
28. *Mobilization and utilization of cyanogenic glucosides: the linustatin pathway.* **Selmar D., Lieberei R., Biehl B.** 1988, *Plant Physiol*, Vol. 86, pp. 711–716.
29. *Cyanogenic lipids: utilization during seedling development of *Ungnadia speciosa*.* **Selmar D., Grocholewski S., Seigler D.S.** 1990, *Plant Physiol*, Vol. 93, pp. 631–636.
30. *Recent developments in chemistry, distribution and biology of the cyanogenic glycosides.* **Nahrstedt, A.** Oxford : Hostettmann, Lea Clarendon Press, 1987.
31. *Cyanogenic glycosides, in Secondary Plant Products.* **Conn, E.E.** 1981, Vol. 7.
32. *beta-Glucosidases: Biochemistry and Molecular Biology, ACS Symposium series 533.* **Conn, E.E.** Washington DC : s.n., 1993, pp. 15-26.

33. *Cyanogenic compounds and angiosperm phylogenie*. **Saupe, S.G.** New York : s.n., 1981, *Phytochemistry and Angiosperm Phylogenie*, pp. 80-116.
34. *Natural cyclopentanoid cyanohydrin glycosides. Part 18. Gynocardin and cyclopentenylglycine in Rawsonia lucida*. **Andersen, L., Clausen, V., Oketch-Rabah, H.A., Lechtenberg, M., Adersen, A., Nahrstedt, A., and Jaroszewski, J.W.** s.l. : Biochemical Systematics and Ecology, Vol. 29 (2001), pp. 219-222.
35. *Kapillarelektrophoretische Untersuchungen an cyanogenen Glykosiden*. **Demmer, P.** Köln : s.n., 2004.
36. *Isolation and structure elucidation of cyanogenic glycosides*. **Nahrstedt, A.** s.l. : Wennesland, Conn, Knowles, Westley, Wissing Academic Press London New York Toronto, 1981.
37. *Constraints on effectiveness of cyanogenic glycosides in herbivore defense*. **Gleadow, R., M. and Woodrow, I.** 2002, *Journal of Chemical Ecology*, Vol. 28, pp. 1301-1313.
38. *Cyanogenesis and foodplants In: Phytochemistry and Agriculture – Proceedings of the Phytochemical Society of Europe,* **Nahrstedt, A.** s.l. : van Beek, Bretler Clarendon Press, Oxford, 1993.
39. *Why are so many foodplants cyanogenic?* **Jones, D.A.** 1998, *Phytochemistry*, Vol. 47, pp. 155-162.
40. *Bioactivation of cyanide to cyanate in sulfur amino acid deficiency: relevance to neurological disease in humans subsisting on cassava*. **Tor-Agbidye, J. et al.** 1999, *Toxicological Sciences*, Vol. 50, pp. 228-235.
41. *Biosynthesis of cyclopentyl fatty acids*. **Cramer, U. and Spencer, F.** 1976, *Biochim. Biophys. Acta*, Vol. 450, pp. 261-265.
42. *The biosynthesis of cyanogenic glucosides in seedlings of cassava (Manihot esculenta Crantz)*. **Koch, B., V.S.Nielsen, B.A. Halkier, C.E.Olsen and B.L. Moller.** 1992, *Arch. Biochem. Biophys.*, Vol. 292, pp. 141-150.
43. *Cyanogenic glucosides: the biosynthetic pathway and the enzyme system involved*. **Halkier, B.A., H.V. Scheller, and Moller, B.L.** Chichester : John Wiley and Sons. Ltd., 1988, *Ciba Symposium*, Vol. 140, pp. 49-66.
44. *The biosynthesis of cyanogenic glucosides in higher plants*. **Halkier, B.A. and B.L. Moller.** 1990, *J.Biol.Chem.*, Vol. 265, pp. 21114-21121.
45. *Cyanogenic glycosides*. **Møller B.L., Poulton J.E.** s.l. : Academic Press, London, 1993.
46. *Cyanogenic and phenylpropanoid glucosides from Prunus grayana*. **Shimomura, H.Y. Sashida, and T. Adachi.** 1987, *Phytochemistry*, Vol. 26, pp. 2365-2366.
47. *Prunasin-6'-malonate, a new cyanogenic glucoside from Merremia dissecta*. **Nahrstedt, A., P.S.Jensen and V.Wray.** 1989, *Phytochemistry*, Vol. 28, pp. 623-624.
48. *Sur la biogene'se du glucoside cyanoge'ne'tique des feuilles de laurier-cerise (Prunus lauro-cerasus)*. **Mentzer C., Favre-Bonvin J.** s.l. : C R Acad Sci Ser III Sci Vie, 1961, Vol. 253, pp. 1072-1074.

49. *Studies on cyanogenic glucoside of Sorghum vulgare*. **Akazawa T., Miljanich P., and Conn E.E.** 1960, *Plant Physiol* , Vol. 35, pp. 535–538.
50. *Isolation of the heme-thiolate enzyme cytochrome P-450TYR, which catalyzes the committed step in the biosynthesis of the cyanogenic glucoside dhurrin in Sorghum bicolor (L.) Moench*. **Sibbesen O., Koch B., Halkier B.A., Møller B.L.** 1994, *Proc Natl Acad Sci USA* , Vol. 91, pp. 9740–9744.
51. *Cytochrome P-450TYR is a multifunctional heme-thiolate enzyme catalyzing the conversion of L-tyrosine to p-hydroxyphenylacetaldehyde oxime in the biosynthesis of the cyanogenic glucoside dhurrin in Sorghum bicolor (L.) Moench*. **Sibbesen O., Koch B., Halkier B.A., Møller B.L.** 1995, *J Biol Chem* , Vol. 270, pp. 3506–3511.
52. *Cloning of three A-type cytochromes P450, CYP71E1, CYP98, and CYP99 from Sorghum bicolor (L.) Moench by a PCR approach, and identification by expression in E. coli of CYP71E1 as the oxime-metabolizing cytochrome P450 in the biosynthesis of dhurrin*. **Bak S., Kahn R.A., Nielsen H.L., Møller B.L., Halkier B.A.** 1998, *Plant Mol Biol* , Vol. 36, pp. 393–405.
53. *Transgenic tobacco and Arabidopsis plants expressing the two multifunctional sorghum cytochrome P450 enzymes, CYP79A1 and CYP71E1, are cyanogenic and accumulate metabolites derived from intermediates in dhurrin biosynthesis*. **Bak S., Olsen C.E., Halkier B.A., and Møller B.L.** 2000, *Plant Physiol* , Vol. 123, pp. 1437–48.
54. *Isolation and reconstitution of cytochrome P450ox and in vitro reconstitution of the entire biosynthetic pathway of the cyanogenic glucoside dhurrin from sorghum*. **Kahn R.A., Bak S., Svendsen I., Halkier B.A., Møller B.L.** 1997, *Plant Physiol* , Vol. 115, pp. 1661–1670.
55. *The UDP-glucose:p-hydroxymandelonitrile-O-glucosyltransferase that catalyzes the last step in synthesis of the cyanogenic glucoside dhurrin in Sorghum bicolor. Isolation, cloning, heterologous expression, and substrate specificity*. **Jones P.R., Møller B.L., Hoj P.B.** 1999, *J Biol Chem*, Vol. 274, pp. 35483–35491.
56. *The in vitro substrate regiospecificity of recombinant UGT85B1, the cyanohydrin glucosyltransferase from Sorghum bicolor*. **Hansen K.S., Kristensen C., Tattersall D.B., Jones P.R., Olsen C.E., Bak S., Møller B.L.** 2003, *Phytochemistry* , Vol. 64, pp. 143–151.
57. *Resistance to an herbivore through engineered cyanogenic glucoside synthesis*. **Tattersall D.B., Bak S., Jones P.R., Olsen C.E., Nielsen J.K., Hansen M.L., Hoj P.B., Møller B.L.** 2001, *Science* , Vol. 293, pp. 1826–1828.
58. *Metabolic engineering of dhurrin in transgenic Arabidopsis plants with marginal inadvertent effects on the metabolome and transcriptome*. **Kristensen C., Morant M., Olsen C.E., Ekstrøm C.T., Galbraith D.W., Møller B.L., Bak S.** 2005, *Proc Natl Acad Sci USA*, Vol. 102, pp. 1779–1784.
59. *Immunocytochemical localization of prunasin hydrolase and mandelonitrile lyase in stems and leaves of Prunus serotina*. **Swain E., Poulton J.E.** 1994a, *Plant Physiol* , Vol. 106, pp. 1285–1291.
60. *Enzymatic formation of beta-cyanoalanine from cyanide*. **Floss H.G., Hadwiger L., Conn E.E.** 1965, *Nature* , Vol. 208, pp. 1207–1208.
61. *Utilization of amygdalin during seedling development of Prunus serotina*. **Swain E., Poulton J.E.** 1994b, *Plant Physiol* , Vol. 106, pp. 437–445.

62. *The Arabidopsis thaliana isogene NIT4 and its orthologs in tobacco encode beta-cyano-L-alanine hydratase/nitrilase.* **Piotrowski M., Schönfelder S., Weiler E.W.** 2001, J Biol Chem , Vol. 276, pp. 2616–2621.
63. *Cyanide metabolism in higher plants: cyanoalanine hydratase is a NIT4 homolog.* **Piotrowski M., Volmer J.J.** 2006, Plant Mol Biol , Vol. 61, pp. 111–122.
64. *Evolution of heteromeric nitrilase complexes in Poaceae with new functions in nitrile metabolism.* **Jenrich R., Trompetter I., Bak S., Olsen C.E., Møller B.L., Piotrowski M.** 2007, Proc Natl Acad Sci USA , Vol. 104, pp. 18848–18853.
65. *Maize nitrilases have a dual role in auxin homeostasis and b-cyanoalanine hydrolysis.* **Kriechbaumer V., Park W.J., Piotrowski M., Meeley R.B., Gierl A., Glawischnig E.** 2007, J Exp Bot , Vol. 58, pp. 4225–4233.
66. *The natural occurring cyanogenic glycosides.* **Seigler, D.** Oxford : s.n., 1977, Progress in Phytochemistry, Vol. 4, pp. 83-120.
67. *Recent developments in the chemistry and biology of cyanogenic glycosides and lipids.* **Seigler, D.S.** 1981a, Rev. Latinoamer. Quim., Vol. 12, pp. 39-48.
68. *Cyanogenic glycosides and lipids: structural types and distribution.* **Seigler, D.S.** London : s.n., 1981b.
69. *Corrected structures of passicoriacin, epicoriacin and epitetraphyllin B and their distribution in the Flacourtiaceae and Passifloraceae.* **Seigler, D.S. and K.C.Spencer.** 1989, Phytochemistry, Vol. 28, pp. 931-932.
70. *Cyanogenic variation in some Midwestern U.S. plant species.* **Aikman, K.D., Bergmann, J.E.Ebinger, and D.Seigler.** 1996, Biochem. Syst. Ecol., Vol. 24, pp. 637-645.
71. *Specificity of action of allelochemicals: Diversification of glycosides in: Allelochemicals: Role in Agriculture and Forestry.* **Spencer, K.** [ed.] G.R. Wallner. Washington D.C. : s.n., 1987. ACS Symposium Series. Vol. 330, pp. 275-288.
72. *Localization and catabolism of cyanogenic glycosides, in Cyanide Compounds in Biology .* **J.E., Poulton.** [ed.] D. Evered and S. Harnett. s.l.: John Wiley & Sons, Ltd., 1988. Ciba Symposium . Vol. 140, pp. 67-91.
73. *Opinion of the Scientific Panel on Food Additives, Flavourings, Processing Aids and Materials in Contact with Food (AFC) on hydrocyanic acid in flavourings and other food ingredients with flavouring properties. Question number EFSA-Q-2003-145; Adopted on 7 October 2004*
74. *Diagnosis and treatment of human poisoning.* **Ellenhorn, M.J. and Barceloux, D.G.** New York : Elsevier Science Publishing Company, 1988, Medical toxicology.
75. *Toxicological profile for cyanide. Draft for public comment. Prepared for the U.S. Public Health Service by Technical Resources, Inc., (ATSDR), Agency for Toxic Substances and Disease Registry.* s.l. : Oak Ridge National Laboratory, 1988.

76. *A review of cyanide concentrations found in human organs — a survey of literature concerning cyanide metabolism, "normal," nonfatal, and fatal body cyanide levels.* **Ansell, M. and Lewis, F.A.S.** 1970, *J. Forensic Med*, Vol. 17, pp. 148-155.
77. *The content of cyanide in humans from cases of poisoning with cyanide taken by mouth. With a contribution to the toxicology of cyanides.* **Halstrom, F. and Moller, K.O.** 1945, *Acta Pharmacol*, Vol. 1, p. 18.
78. *Cyanide poisoning.* **Curry, A.S.** 1963, *Acta Pharmacol. Toxicol.*, Vol. 20, p. 291.
79. *The determination of cyanide in biologic fluids by microdiffusion analysis.* **Feldstein, M. and Klendshoj, N.C.** 1954, *J. Lab. Clin. Med.*, Vol. 44, p. 166.
80. *Hydrogen cyanide and cyanides.* **Anonymous.** 1983, *Saf. Pract.*, Vol. 1, p. 22.
81. *Cyanide health advisory.* **U.S. Environmental Protection Agency.** s.l. : Office of Drinking Water, 1985.
82. *Health effects criteria document for cyanide.* **U.S. Environmental Protection Agency.** s.l. : Office of Drinking Water, 1985.
83. *Drinking water criteria document for cyanide.* **U.S. Environmental Protection Agency.** s.l. : Office of Drinking Water, 1987.
84. *Chronic toxicity for rats of food treated with hydrogen cyanide.* **Howard, J.W. and Hanzal, R.F.** 1955, *J. Agric. Food Chem*, Vol. 3, p. 325.
85. *Cyanide poisoning: an uncommon encounter.* **Holland, D.J.** 1983, *J. Emerg. Nurs.*, Vol. 9, p. 138.
86. *Handbook of poisoning: prevention, diagnosis and treatment.* **Dreisenbach, R.H. and Robertson, W.O.** Norwalk : Appleton and Lange, 1987.
87. *Possible role of cyanide and thiocyanate in the etiology of endemic cretinism.* **Ermans, A.M., Delange, F., Van Der Velden, M. and Kinthaert, J.** 1972, *Adv. Exp. Med. Biol.*, Vol. 30, p. 455.
88. *Role of cassava in the etiology of endemic goiter and cretinism.* **Ermans, A.M., Mbulamoko, N.M., Delange, F. and Ahlvarartia, R.** s.l. : International Development Research Centre, Ottawa, 1980, p. 182.
89. *Allgemeine und spezielle Pharmakologie und Toxikologie.* **Forth, W., Henschler, D. and W., Rummel.** s.l. : Bibliographisches Institut & F.A. Brockhaus AG, 1987. ISBN-3-411-03150-6.
90. *Apricot Kernel: Physical and Chemical Properties.* **Alpaslan M. and Hayta, M.** Malatya, Turkey : İnönü University Department of Food Engineering, 2006.
91. *Chemical Composition of Different Varieties of Apricots and Their Kernels Grown in Ladakha Region.* **Kappor, N., K.L. Bedi, and A.K. Bhatia.** 1987, *J. Food Sci. Technol*, Vol. 24, pp. 141-143 .
92. *Characterization of the Seed Oil and Meal from Apricot, Cherry, Nectarine, Peach and Plum.* **Kamel, B.S., and Y. Kakuda.** 1992, *J. Am. Oil Chem. Soc.* , Vol. 69, pp. 493-494 .
93. *Chemical and Physical Properties of Apricot Kernel, Apricot Kernel Oil and Almond Kernel Oil.* **Hallabo, S.A.S., F.A. El-Wakeil, and M.K.S. Morsi.** 1977, *Egyptian J. Food Sci.*, Vol. 3, pp. 1-6 .

94. *Composition of New Zealand Apricot Kernels*. **Beyer, R., and L.D. Melton**. 1990, N.Z. Crop Hortic. Sci. , Vol. 18, pp. 39–42 .
95. *In vitro Digestibility, Physico-chemical and Functional Properties of Apricot Kernel Proteins*, **Abd El Aal, M.H., M.A. Hamza, and E.H. Rahma**. 1986, Food Chem. , Vol. 19, pp. 197-212 .
96. *Composition of Some Apricot (*Prunus armeniaca* L.) Kernels Grown in Turkey*. **Özcan, M.** 2000, Acta Aliment., Vol. 29, pp. 289–293 .
97. *Evaluation of Apricot Kernel Proteins*. **Moussa, M.M., and M.A.B. Taiseer**. 1980, Alexandria J. Agric. Res. , Vol. 28, pp. 133–137 .
98. *Mechanical Behaviour of Apricot Pit Under Compression Loading*. **Vursavus, K., and F. Özgüven**. J. Food Eng., Vol. 65, pp. 255–261.
99. *Some Physical Properties of Hacıhaliloglu Apricot Pit and Its Kernel*. **Gezer, I., H. Haciseferoğulları, and F. Demir**. 2002, J. Food Eng. , Vol. 56, pp. 49–57 .
100. *Antioxidant properties of roasted apricot (*Prunus armeniaca* L.) kernel*. **Alpaslan, D. et al.** 2007, Food Chemistry , Vol. 100, pp. 1177–1181.
101. *Some characteristics and fatty acids composition of wild apricot (*Prunus pseudoarmeniaca* L.) kernel oil*. **Kaya, C., et al.** 4, 2008, Asian Journal of Chemistry, Vol. 20, pp. 2597-2602.
102. *Chemical composition of bitter apricot kernels from Ladakh, India*. **Dwivedi, D. H. and Ram, R. B.** s.l. : Proceedings of the International Symposium on Plants as Food and Medicine, 2006, 2008, Acta Horticulturae, pp. 335-338.
103. *Determination of Tocopherols and Sterols by Capillary Gas Chromatography*. **Slover, H.T., Jr., H.R. Thompson, and G.V. Merola**. 1983, J. Am. Oil Chem. Soc. , Vol. 60, pp. 1524–1528.
104. *Lehrbuch der Lebensmittelchemie, 6. Auflage*. **Belitz, H. D. , W. Grosch, P. Schieberle**. s.l. : Springer Verlag, 2008. 3540732012.
105. *Chemical Composition of Bitter and Sweet Apricot Kernels*. **Femenia, A., C. Rossello, A. Mulet, and J. Canellas**. 1995, J. Agric. Food Chem. , Vol. 43, pp. 356–361 .
106. *Unconventional Protein Sources: Apricot Seed Kernels*. **Gabrial, G.N., F.I. El-Nahry, M.Z. Awadalla, and S.M. Girgis**. 1981, Z. Ernährungswiss., Vol. 20, pp. 208–215.
107. *The Chemistry of *Prunus armeniaca**. **Joshi, S., R.K. Srivastava and D.N. Dhar**. 1986, Br. Food J. , Vol. 88, pp. 74–78, 80 .
108. *Egyptian Apricot Kernels Seeds*, . **Salem, S.A., and F.M.A Salem,** 1973, Dtsch. Lebensm. Rundsch., Vol. 69, pp. 322–324.
109. *Toxicological, Nutritional and Microbiological Evaluation of Tempe Fermentation with *Rhizopus oligosporus* of Bitter and Sweet Apricot Seeds*. **Tunçel, G., M.J.R. Nout, L. Brimer, and D. Gökten**. 1990, Int. J. Food Microbiol., Vol. 11, pp. 337–344 .
110. *Apricot Stone Kernels as a Valuable Commercial By-product*. **Normakhmatov, R., and T. Khudaishukurov**. 1973, Konservn. i Ovoshchesush. Prom., Vol. 10, pp. 32–33.

111. *Characterization of sour cherries (Prunus cerasus) kernel oil cultivars from Banat.* **Popa, V.M., et al.** 2011, Journal of Agroalimentary Processes and Technologies , Vol. 17(4), pp. 398-401.
112. *Anlage zur Akkreditierungsurkunde DAP-PL-3942.00 nach DIN EN ISO/IEC 17025:2005.* **Prüfwesen, DAP Deutsches Akkreditierungssystem.** 12247 Berlin : IfP Privates Institut für Produktqualität GmbH Teltowkanalstraße 2, 2007.
113. **DAP.** [Online] <http://www.dap.de/anl/PL394200.pdf>.
114. *ÖNORM EN 16160 Ausgabe: 2010-11-15 Futtermittel — Bestimmung von Blausäure mittels HPLC.* **Institute, Austrian Standards.** Wien: Austrian Standards Institute, 2010.
115. *Official of Analysis of the Assoc. of Official Analytical Chemists.* **Horwitz, W. (ed).** Washington D.C.: s.n., 1980, p. 433.
116. *Poisonous Plants of the U.S. and Canada.* **Kingsbury, J.M.** 1964.
117. *Methods for the detection and quantitative determination of cyanid ein plant material.* **Brinker, A.M. and Seigler, D.S.** 1989, Phytochem. Bull., Vol. 21, pp. 24-31.
118. *Determination of cyanide and cyanogenic glycosides of plants.* **Brinker, A.M. and D.S. Seigler.** Berlin : Springer Verlag, 1992, Modern methods of plant analysis.
119. *Absence of cyanogenesis from Droseraceae.* **Nahrstedt, A.** 1980: s.n., Phytochemistry , Vol. 19, pp. 2757-2758.
120. *Stable reagents for the determination of cyanide by modiefies König reaction.* **Lambert, J.L., J. Ramasamy and J.V.Paukstelis.** 1975, Anal. Chem., Vol. 47, pp. 916-918.
121. *Determination of cyanide and cyanogenic compounds in biological systems.* **Brimer, L.** Chinchester : John Wiley and Sons, Ltd., 1988, Cyanide, Vol. 140, pp. 177-200.
122. *Cyanogenic glycosides and cyanohydrins in plant tissue. Qualitative and quantitative determination by enzymatic post column cleavage and electrochemical detection after seperation by HPLC.* **Brimer, L. and L.Dalgaard.** 1984, J.Chromatogr., Vol. 303, pp. 77-88.
123. *Methods of liberating and etimating hydrocyanic acid from cyanogenic plant material in Cyanide in Biology.* **Nahrstedt, A., N.Erb and H.Zinsmeister.** London: s.n., 1981, Academic Press, pp. 461-471.
124. *Isolation and characterization of two cyanogenic  $\beta$ -glucosidases from flax seeds.* **Fan, T.W. and E.E. Conn.** 1985, Arch. Biochem. Biophys., Vol. 243, pp. 361-373.
125. *A rapid and sensitive spectrophotometric assay for prunasin hydrolase activity employing purified mandelonitrile lyase.* **Gross, M., G.H. Jacobs and J.E. Poulton.** 1982, Anal. Biochem., Vol. 119, pp. 25-30.
126. *The aglycone specificity of plant  $\beta$ -glucosidases.* **Hösel, W. and E.E. Conn.** 1982, Trends Biochem. Sci., Vol. 7, pp. 219-221.
127. *Spezifische Glucosidasen für das Cyanglucosid Triglochinin-Reinigung und Charakterisierung von  $\beta$ -Glucosidasen aus Alocasia macrorrhiza.* **Hösel, W. and A. Nahrstedt.** 1975, Hoppe-Seyler's Z. Physiol. Chem., Vol. 356, pp. 1265-1275.



128. *Characterization of  $\beta$ -glucosidases with high specificity for the cyanogenic glucoside dhurrin in Sorghum bicolor (L.) Moench seedlings.* **Hösel, W., I. Tober, S.H. Ecklund and E.E. Conn.** 1987, Arch. Biochem. Biophys., Vol. 252, pp. 152-162.
129. *Quantification of benzaldehyde and its precursors in montmorency cherry (Prunus cerasus L.) kernels.* **Chandra, A. and Nair, M. G.** 1993, Phytochemical Analysis, Vol. 4, pp. 120-123.
130. *Quantitative determination of amygdalin epimers from armeniacaee semen by liquid chromatography.* **Koo, J.Y., et al.** s.l.: Elsevier B.V., 2005, Journal of Chromatography, B: Analytical Technologies in the Biomedical and Life Sciences, Vol. 814(1), pp. 69-73.
131. *Prevention of epimerization and quantitative determination of amygdalin in Armeniacaee Semen with Schizandrae Fructus solution.* **Joo W.S., Jeong J.S., Kim H., Lee Y.M., Lee J.H., Hong S.P.** 12 2006, Arch Pharm Res, Vol. 29(12), pp. 1096-101.
132. *Improved gas chromatography of amygdalin and its diastereomer.* **Kawai S., Y. Takayama.** 1980, Journal of Chromatography A, Vol. 197 (2), pp. 240-5. 0021-9673.
133. *Gas chromatographic enzymic determination of amygdalin.* **Kawai, S., K. Kobayashi, Y. Takayama.** 2, s.l.: Elsevier B.V., Journal of Chromatography A, Vol. 210, pp. 342-5.
134. *Micellar electrokinetic chromatography for the analysis of D-amygdalin and its epimer in apricot kernel.* **Kang, S.H., Jung, H., Kim, N., Shin, D.H. and Chung, D.S.** 2000, Journal of Chromatography A, Vol. 866, pp. 253-259.
135. *Detection of Abnormally High Amygdalin Content in Food by an Enzyme Immunoassay.* **A-Yeon Cho, Kye Sook Yi, Jung-Hyo Rhim, Kyu-Il Kim, Jae-Young Park, Eun-Hee Keum, Junho Chung, and Sangsuk Oh.** 2006, Molecules and Cells, Vols. 21, No 2, pp. 308-313.
136. *Blausäure in Steinobstkernen – Quantifizierung und Dekontamination.* **Ingrid Steiner, Anatol Desser.** Österreichische Lebensmittelchemikertage 2010 – Wertbestimmende Inhaltsstoffe in Lebensmitteln, Tagungsband ISBN 978-3-900554-67-5. pp-13-17
137. *Benzaldehyde.* **Brühne, F. and Wright, E.** s.l.: Wiley-VCH Verlag GmbH & Co. KGaA, Weinheim, 2005.
138. *Method for producing bitter almond essential oil.* **Zhao, Z., et al.** 2007, Patent 200910022665.
139. *Simultaneous distillation-extraction: preparative recovery of volatiles under mild conditions in batch or continuous operations.* **Pollien, P., et al.** Nestle Research Centre, NESTEC Ltd, Lausanne, Switz.: John Wiley & Sons Ltd, 1998, Flavour and Fragrance Journal, Vol. 13(6), pp. 413-423.
140. [www.roempp.com](http://www.roempp.com) . [Online] 12 2009.
141. *Microwave processing method of semen Armeniacaee Amarum.* **L., Zhang, Q., Yao and H., Xie.** 1991, China journal of Chinese materia medica, Vol. 16(3), pp. 146-7.
142. *Picrate paper kits for determination of total cyanogens in cassava roots and all forms of cyanogens in cassava products.* **Bradbury, M.G., Egan, S.V. and J.H. Bradbury.** 1999, Journal of the Science of Food and Agriculture, Vol. 79, pp. 593-601.

143. *Simple Picrate Paper Kit for Determination of the Cyanogenic Potential of Cassava Flour*. **Egan, S.V., Yeoh, H.H. and Bradbury, J.H.** Division of Botany and Zoology, Australian National University, Canberra, ACT 0200, Australia : s.n., 1998, J Sci Food Agric.
144. *Total cyanide determination of plants and foods using the picrate and acid hydrolysis methods*. **Haque, M.R. and Bradbury, J.H.** Division of Botany and Zoology, Australian National University, Canberra, ACT 0200, Australia : s.n., 2002, Food Chemistry , Vol. 77, pp. 107–114.
145. *Spectrophotometric Determination of Trace Amounts of Free Cyanide in Prussian Blue*. **Bulcke, G.J. Willekens and A. Van Den.** Brussels : s.n., 1979, Analyst, pp. 525-530.
146. *Zur Kenntnis der sogenannten Isopurpurat-Reaktion der Pikrinsäure*. **Auterhoff, H. and Heinzelmann, M.** 8, 1971, Archiv der Pharmazie, Vol. 304, pp. 624–627.
147. *Guide to Quality in Analytical Chemistry - An Aid to Accreditation*. **CITAC.** s.l. : CITAC and Eurachem, 2002.
148. *Merck Index, 12th Ed., #8742*. 1996.
- 149: AGES. Presseinformation der AGES vom 3.8.2006. [Online] 29.3.2010. <http://ages.at/ages/ueber-uns/presse/presse-archiv/2006/wien-382006-ages-die-marille-ist-zum-essen-da-ihr-kern-nicht/> (bezogen am 29.3.2010)
- 150: [http://www.laves.niedersachsen.de/portal/live.php?navigation\\_id=20051&article\\_id=73476&psmand=23](http://www.laves.niedersachsen.de/portal/live.php?navigation_id=20051&article_id=73476&psmand=23) (bezogen am 24.2.2015)
- 151: [http://www.bfr.bund.de/de/a-z\\_index/amygdalin-9426.html](http://www.bfr.bund.de/de/a-z_index/amygdalin-9426.html) (bezogen am 24.2.2015)
- 152: REGULATION (EU) No 1169/2011 OF THE EUROPEAN PARLIAMENT AND OF THE COUNCIL of 25 October 2011 on the provision of food information to consumers.