

A Case Study On Coupling Thermo-dynamical and Electro-mechanical Models in Modelica-based Simulators

Matthias Rößler^{1,2}

¹dwh Simulation Services, Neustiftgasse 57-59, 1070 Vienna, Austria; matthias.roessler@dwh.at

²Institute for Analysis and Scientific Computing, Vienna University of Technology, Wiedner Hauptstraße 8-10, 1040 Vienna, Austria

Simulation Notes Europe SNE 23(3-4), 2013, 155 - 160
 DOI: 10.11128/sne.23.tn.10211
 Received: March 10, 2013 (Selected I3M 2012 Postconf. Publ.);
 Extended Revised: Sept. 15, 2013; Accepted: Nov. 20, 2013;

Abstract. Due to higher ecological awareness and more stringent environmental laws the necessity of lowering the energy consumption of manufacturing plants rises. Therefore the possibility to optimize a planned production hall becomes more and more important. The research project INFO, a project of the Vienna University of Technology in cooperation with industry partners and supported by the FFG, the Austrian Research Promotion Agency, creates an overall simulation of a cutting factory. Overall models of such proportions deal with a lot of difficulties, one of them is that through the interdisciplinarity of the problem there are many submodels that have to be coupled to get to the overall simulation. This work studies one possible solution for this problem, namely the coupling of different model parts in one simulator. First the two partial models are described and their simulation results validated against measurement data. Afterwards the models are coupled and possible problems are analysed and the approach is evaluated.

Introduction

As the necessity of lowering the energy consumption of manufacturing plants rises due to increased energy costs and environmental awareness, the possibility to optimize the energetic behaviour of a production hall becomes more and more important. Especially during the planning phase, saving potential is very high. Therefore the research project INFO, a project of the Vienna University of Technology in cooperation with industry partners and supported by the FFG, the Austrian Re-

search Promotion Agency, creates an overall simulation of a cutting factory. The holistic approach of the project makes it necessary, that models from different physical domains have to be built, taking into account microscopic and macroscopic processes, like machines, the building hull or influences of the weather ([1]). Therefore one important question the project had to solve, was how to couple models from different domains.

In this paper the coupling of different model parts in one simulator will be studied. Therefore two model parts, a room model and a model of a machine tool are developed and afterwards coupled. The models are intentionally kept simple to identify the problems that occur because of the coupling of the model parts rather than numerical problems because of the size of the resulting equation system. The model of the machine tool is a linear guiding device and for the room model a compartment model is chosen. For both models exist test rigs, so they can be validated against measurement data.

Additionally a comparison of two different simulators, Dymola and MapleSim, is made. Both simulators rely on the modelling approach of Modelica, so their numerical behaviour and efficiency can be studied and their suitability for coupling models from different domains can be evaluated.

In the first chapter those two simulators are presented. Then the two models, the room model and the machine model are described in detail. Afterwards the coupling of the two models is realised and the results are presented. Finally an outlook to possible future work is given.

1 Simulators

The Modelica Standard, which is maintained by the Modelica Association, uses an object-oriented approach

to model physical systems. Using this approach a system is modelled by building an acausal block-diagram, where every block represents a real component, for instance a linear translational spring or an electrical resistor. By using the defining equations for each component, which are stored in the representing blocks, and additional equations, that result from connecting the blocks with acausal connections, an equation system is built, which can be solved by a simulator. It is important to note, that neither in the components nor in the connections a causality between the variables is assumed.

This approach works in various physical domains such as mechanics, electrical engineering or thermodynamics, which makes it possible to build multi-domain models. The Modelica Standard only provides a language to describe models in such a manner. To simulate the models a simulator, which understands this language and provides the necessary algorithms to derive and solve the resulting equation system, has to be used. The current version of the Modelica Standard is version 3.2 ([2]).

As mentioned before two different simulators are used in this paper: Dymola and MapleSim. These simulators shall now be described briefly laying a focus on the functionalities used in this paper.

Dymola. The past of Dymola is closely related to Modelica as the Modelica Standard is developed from Dymola. Because of this Dymola can be seen as the simulator who understands the Modelica language best. Models can be built either graphically or textually. The version used in this paper is Dymola 2012, which supports the Modelica Standard 3.2. In this version of the Modelica Standard all dissipative components have an optional heatport, which allows the use of the lost energy in an additional thermodynamical system. This feature is very useful for the purposes of this paper.

MapleSim. MapleSim is developed by MapleSoft. Models can only be built graphically, but new components can be defined using either the Modelica language or a built in Maple function, where only the equations and ports have to be defined and a Modelica component is created automatically. MapleSim supports Modelica Standard 3.1, where the optional heatport is only used in the electrical resistor component; this means that for the other dissipative components the lost energy has to be measured to be used in a thermodynamical model.

2 Submodels

The system that we want to investigate in this paper is a machine tool that stands in a room. The waste heat of the machine heats up the room and is distributed equally in it over time.

2.1 Room model

The surrounding of the machine is subdivided into compartments. The individual compartments can be seen as boxes of a certain size containing air. In reality such a model would have to take into account many things, so several assumptions are made for the model to simplify it:

1. The temperature is constant within the compartment
2. Heat flow is only permitted over the contact surface of adjacent compartments
3. The only way of heat transport is conduction, no convection or radiation is taken into account.
4. The walls of the room are perfectly isolated. No heat flow over the boundaries is permitted, so there is no energy lost in the system.
5. The thermal parameters of the air are assumed to be independent from the temperature and therefore constant over time.

Compartments. Each compartment is implemented as a submodel. Figure 1 shows the basic structure of the compartment.

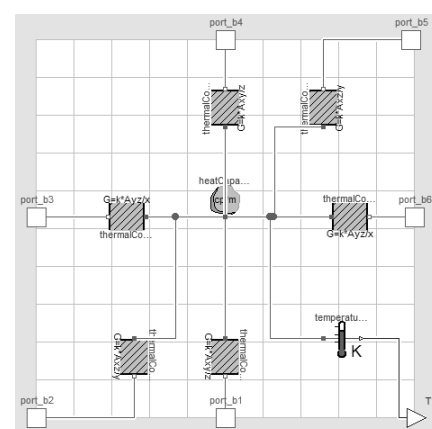

Figure 1: Basic structure of a single compartment in Dymola.

It consists of a heat capacitor that can be seen in the middle of the compartment. This satisfies the first assumption of the room model. In accordance to assumptions 2 and 3 the conductor blocks ensure the heat flow in the 6 possible directions. Additionally a temperature sensor to measure the temperature in the compartment is added.

In Table 1 the parameters for the compartment block are listed. The size of the compartment is given by the expansion along the x -, y - and z -axis, which have to be adjusted to the used compartments. Other parameters that are used by the components within the compartment are derived directly like the volume or the area of the faces of the compartment. Also the thermal parameters of the medium, that the compartment is filled with, are shown. Those parameters are the specific thermal capacity, the density and the conductivity of the medium. In the following simulations the parameters are set to values that correspond to the thermal properties of air at 20°C .

The components used in the compartment submodel use these parameters to calculate the heat flow between the compartments. The thermal mass of the heat capacitor and therefore of the compartment is derived from the volume and the specific thermal capacity that is given in the parameters. In the heat capacitor component the temperature of the compartment is calculated.

x	0.2675	c_p	1012
y	0.17	ρ	1.204
z	0.12	k	0.0257

Table 1: Parameter-set.

To derive the heat flow through the conductor components, the simple geometry of the compartment is used. The heat flow is then only dependent on the area of the contact surface between two compartments A , the distance between the centres of the two δ , the thermal conductance of the medium k and their temperature difference ΔT :

$$Q_{flow} = k \frac{A}{\delta} \cdot \Delta T \quad (1)$$

Validation. For the validation of the model a test rig was built to see if the assumptions made for this model are too restrictive. Therefore a Styrofoam box was used, where eight temperature sensors were attached inside. As a heat source a soldering rod was used. The parameters of the eight compartments used in this model are

depicted in Table 1, the test rig and the model can be seen in Figure 2.

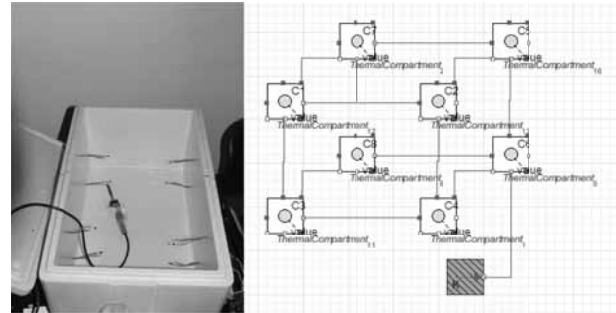

Figure 2: Test rig for the room model and model in MapleSim.

The measurement data of the test rig can be seen in Figure 3, the simulation results of Dymola and MapleSim in Figure 4.

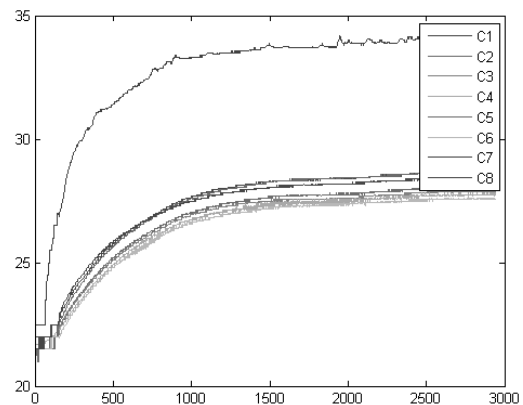

Figure 3: Measurement data of test rig for room model.

It can be seen that the qualitative behaviour of the temperature in the compartment, where the heat source is attached, matches the measurement data, but the magnitude of the temperature rise in the simulation is disproportional. An explanation for this effect can be that the test rig is not isolated well enough, so the assumption of the perfectly isolated walls cannot be met. Further the other compartments heat up much more uniformly in the experiment than in the simulation. This has two main reasons. First in the test rig the heat can flow in any direction, whereas in the simulation it is only permitted in six directions. Second the convection, which is neglected in the simulation, allows a much smoother heat distribution in the experiment.

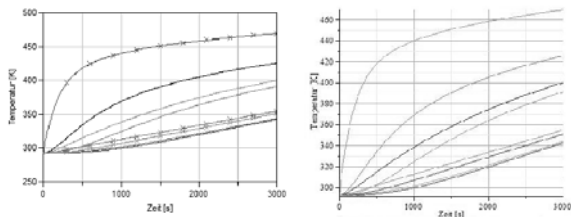

Figure 4: Simulation results from Dymola and MapleSim.

The comparison of the simulation results shows that the two simulators work equally well for this model.

2.2 Machine model

The linear guiding device is a simple part of a machine tool; it consists of a permanent magnet DC motor that drives a thread bar via a gear belt. The thread bar moves a cart, where the sliding mass is attached. The test setup for the validation of the model is provided by the Institute for Production Engineering and Laser Technology from the Vienna University of Technology ([3]) and is shown in Figure 5.

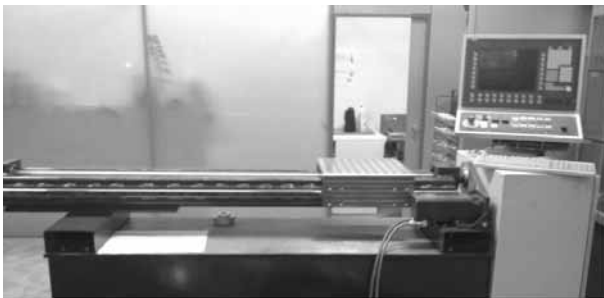

Figure 5: Test setup of linear guiding device.

For the model components of the Modelica Standard Library were used, the general structure of the model can be seen in Figure 6. It shows that the structure of the model is very similar to the structure of the real system, which is an important advantage of this modelling approach.

Due to the graphical representation of the model and the modular structure, the underlying equations are not easy to see, so the individual components of the model are described the following sections.

Permanent magnet DC motor. The electric motor is implemented as a permanent magnet DC motor model. The motor model was updated in version 3.2

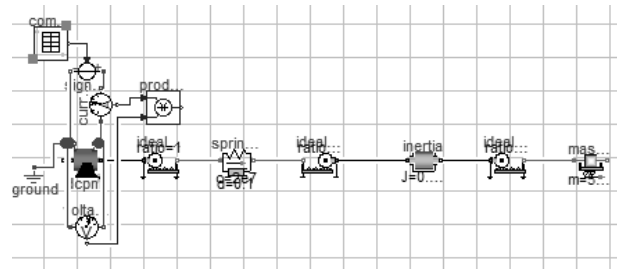

Figure 6: Model of the Machine Tool in Dymola.

of Modelica, so the models in Dymola and MapleSim differ in their complexity. The Dymola model takes different power losses into account, such as friction losses or losses in the stray load [4], which can not be directly modelled in MapleSim due to the lower Modelica version. To ensure comparability between the two models despite the different DCPM models, the parameters, that are used to calculate these losses, are set to zero and the only losses that are taken into account are the ones in the armature circuit, which is modelled as an inductor and a resistor connected in series. As already mentioned the resistor in MapleSim has an optional heatport as well and therefore the loss in this component can be calculated in both simulators in the same way.

Gear belt. The spring constant of a gear belt is always given in a translational manner in the data sheets. Therefore it is modelled as a linear translational spring-damper element, where the damping constant of the component is chosen in such a way that a swinging up of the spring is prevented. The transition between the rotational and translational mechanical domain is made through ideal gears, so no power is lost in this transition.

Thread bar. The defining parameters for a thread bar are its inertia and its lead. So the thread bar in this model consists of an inertia component and an ideal gear, where the transition ratio is directly proportional to the lead of the thread bar.

Cart and mass. As the cart and the mass that shall be moved are rigidly connected to each other, they can be modelled as one mass. The component chosen for the model is a mass with stop and friction, where also a hard stop can be implemented, but is not considered for this model.

The parameters of the friction were chosen in such a way, that the measurement data was approximated

properly by the simulation results. This can be justified by the fact that the other mechanical components in the model are implemented at least nearly ideal, so the friction component can be seen as a cumulative component, where all the mechanical frictions in the system are considered.

Voltage Source. The input for the voltage source, that supplies the voltage for the electric motor, is stored in a time table. The entries of the table are derived from measurement data. The data was taken over the course of one displacement process. The measuring equipment was placed in front of the power electronics, so the first step of adjusting the data was to subtract the mean value of the data points in the idle state, because the power electronics was not considered in the model. Additionally, because the measured signal was very noisy, the data was filtered by a very simple algorithm. Every data point v_i is replaced with the mean value of $v_{i-2}, v_{i-1}, v_i, v_{i+1}, v_{i+2}$. This procedure is repeated ten times. The result of the filtering is depicted in Figure 7.

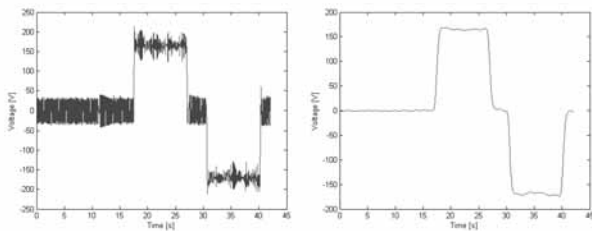

Figure 7: Input-Signal of Voltage Source before and after filtering.

2.3 Simulation results

To compare the simulation results with the measurement data the power consumption of the electric motor was used. Therefore the voltage and current in the armature circuit of the motor was measured in the model and then multiplied. Given the model does not account for the power electronics, the power consumption of the controller had to be added to simulation results, so they can be compared to the measurement data. Figure 8 and 9 show the results of the simulation runs in Dymola and MapleSim compared to the measurement data. Additionally the mean values of the power consumptions over time are shown.

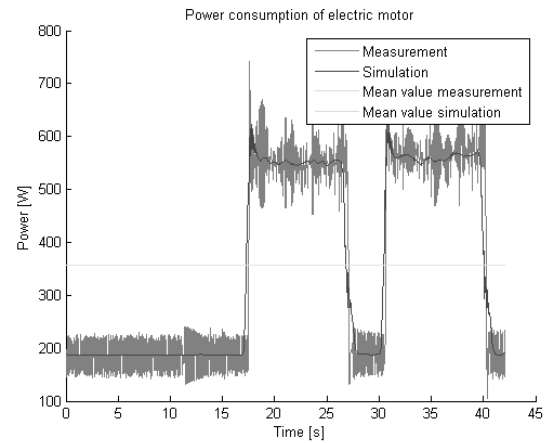

Figure 8: Simulation results in Dymola.

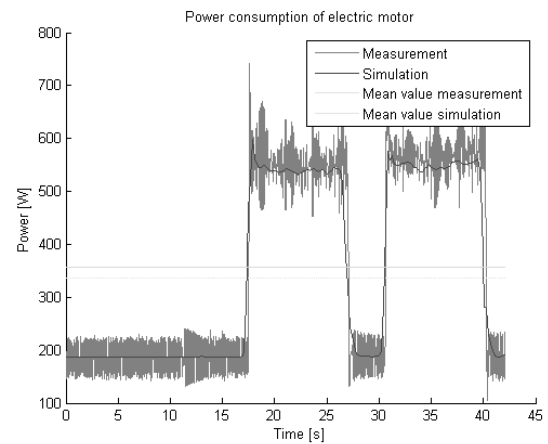

Figure 9: Simulation results in MapleSim.

A qualitative analysis shows that the results of both simulators match the measurement data very well. Comparing the two simulators it can be seen that the results are slightly different. Also the mean values over the displacement period are different. Dymola matches the measurement data better in this regard, whereas the machine in MapleSim consumes less power over the course of one period.

3 Coupling

In a final step the two models are coupled into one model. The energy lost in the dissipative components of the machine model is used as heat source for the room model. In the coupled model the machine stretches across two compartments. The heat loss of the electric motor is a heat source of one compartment and the

heat lost through friction in the mechanical parts heats up another compartment. Figure 10 shows the coupled model.

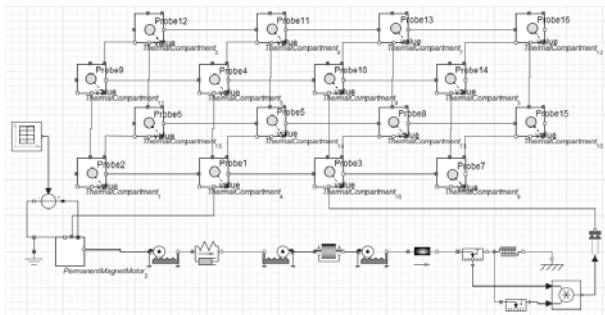

Figure 10: Coupled model in MapleSim.

To model a machine hall the compartments in this model are much larger than in the test scenario. The machine hall is assumed to have an expansion of 20m x 10m x 6m. Additionally changes in the machine model had to be made. In Dymola it was possible to activate the optional heatports to get the heat loss in the dissipative elements, whereas in MapleSim it was necessary to build a new permanent magnet DC motor component to retrieve the energy lost in the resistor of the armature circuit and to measure force and velocity at the friction component to calculate the heat from this component. Figure 11 depicts the simulation results in Dymola for a simulation time of six hours.

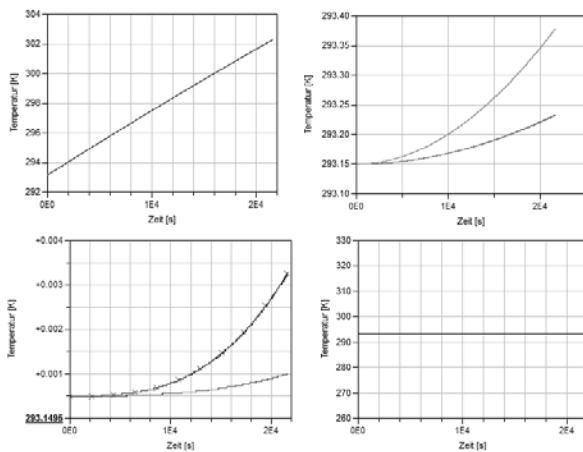

Figure 11: Simulation results of the coupled model in Dymola.

More interesting than the simulation results itself are the computation times it took to simulate the model. The two simulators both needed about half an hour to compute this relatively simple model. Seeing as the

used models are too simplified to represent a real machine or machine hall leads to the conclusion that for more complicated models a coupling in one simulator is nearly impossible even with bigger computational power. The main problem in coupling the two models arises because of the different time constants of the model parts. As the time constants for the electrical and the mechanical part of the machine model are similar, the thermal time constant is proportional to the thermal mass of the studied system. This has the effect that very small steps have to be made by the solver algorithm compared to the relatively large simulation time and in each of these time steps the whole thermal model has to be calculated, which would not be necessary because of the slowly changing behaviour of the system. This can also lead to numerical problems through loss of significance.

4 Conclusion

Due to the simplicity of these models it is possible to couple them in one simulator. But for more complex models the computational effort to simulate the models would rise definitely. To simulate a whole production hall over the course of a year is therefore not advisable with this approach. For the machine model it is to say, that it provides satisfactory results if the input signal is smooth enough. The room model is not sophisticated enough to represent a real room, for that the model assumptions are too restrictive. But the modular construction of the room model allows an easy refinement of the discretization of the model.

References

- [1] Leobner I, Ponweiser K, Neuschwandtner G, Kastner W, Energy Efficient Production – A Holistic Modelling Approach. In *WCST2011-Proceedings*, 62-67. 7th–10th November 2011, London.
- [2] Modelica Corporation, 2010. Modelica – A Unified Object-Oriented Language for Physical Systems Modeling – Language Specification Version 3.2. Available from: <http://www.modelica.org>
- [3] Salvatori, C., 2010, *Energieeffizienz von Werkzeugmaschinen - Planung und Aufbau eines Versuchsstandes zur Untersuchung eines Kugelgewindetriebes*, Bachelorthesis, Vienna UT
- [4] Kral C, Haumer A. Object Oriented Modeling of Rotating Electrical Machines, In: Schmidt, M., eds., *Advances in Computer Science and Engineering*, Croatia: InTech. 2011. 135-160.